

**FAILURE TO READ AND FOLLOW ALL INSTRUCTIONS CAREFULLY BEFORE INSTALLING OR OPERATING THIS CONTROL COULD CAUSE PERSONAL INJURY AND/OR PROPERTY DAMAGE.**

**DESCRIPTION**

F858-1002 is a Field Replacement kit containing a 5088A-101 power supply and an air flow switch for the electronic air cleaner. F859-0381 contains an air flow switch and wiring harness for adding the Air Flow Switch option to the electronic air cleaner.

The 5088A-101 regulated high voltage power supply is designed for use in residential central and portable electronic air cleaners.

The control provides power to operate the ionizing section and collecting plates. Terminals are provided to illuminate an LED indicator during normal operation. The control will extinguish the LED if the cell becomes shorted.

An ozone reduction feature is field selectable and is designed to restrict peak output power without seriously diminishing the efficiency of the air cleaner.

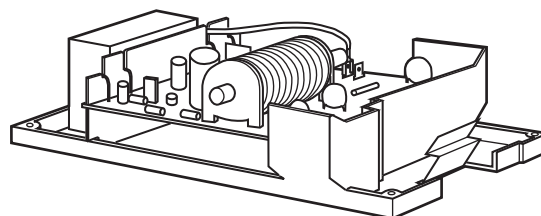

Although this unit may have a different appearance from the power supply it is replacing, it has an equivalent power output. The 5088A-101 is a direct substitute for part numbers F858-0265, F858-0368, F858-0448, F858-0472, F858-0705, F858-0811, F858-0886, F858-0890, F858-0503, F858-0812, F858-1000, F858-1001, and F858-1002 (see INSTALLATION section).

The F859-0381 Air Flow Switch is compatible with F858-1000, F858-1001, F858-1002 (5088A-1XX series), 858-09XX and 858-07XX series power supplies.

**PRECAUTIONS**

THIS INSTALLATION MUST BE PERFORMED BY A QUALIFIED SERVICE REPRESENTATIVE.

Do not exceed the specification ratings.

All wiring must conform to local and national electrical codes and ordinances.

This control is a precision instrument, and should be handled carefully. Rough handling or distorting components could cause the control to malfunction.

Replace the 5088A-101 control as a unit - there are no user serviceable parts.

**! WARNING**

**Do not use on circuits exceeding specified voltage. Higher voltage will damage control and could cause shock or fire hazard.**

**! WARNING**

**Do not repair or modify this unit. Personal injury and/or property damage may occur.**

**! CAUTION**

**To prevent electrical shock and/or equipment damage, disconnect electric power to system at main fuse or circuit breaker box until installation is complete.**

**Label all wires prior to disconnection when servicing controls. Wiring errors can cause improper and/or dangerous operation.**

**This control is not intended for use in locations where it may come in contact with water. Suitable protection must be provided to shield the control from exposure to water (dripping, spraying, rain, etc.).**

**CONTENTS**

Description .....	1
Precautions .....	1
Specifications .....	2
Installation F858-1002 .....	2
Installation F859-0381 .....	3
Operation .....	4
Troubleshooting .....	4

# SPECIFICATIONS

## ELECTRICAL RATINGS [ @ 77°F (25°C) ]:

- Input Voltage:** 120 VAC 60 Hz (nom.)
- Input Current:** 0.3 Amp (max.)
- Output Voltage:** 6.45 KVDC (nom.)
- Output Current:** 0.005 Amp DC (max.)

## TEMPERATURE RANGE:

- Operating:** -40°F to +158°F (-40°C to +70°C)
- Storage:** -40°F to +185°F (-40°C to +85°C)

## HUMIDITY RANGE:

- 10% to 95% RH (non-condensing)

## MOUNTING:

- Surface mount - multipoise

## TERMINATION:

- Line:** Two 1/4" male spade terminals
- Cell:** One 1/4" male spade terminal
- LED:** Two 3/16" x 0.02" male spade terminals
- Supply Ground:** One 1/4" male spade terminal
- Aux Ground:** Two leaf spring contacts

# INSTALLATION - F858-1002

## Power Supply

### IMPORTANT!

The 5088A power supply is not compatible with some previous air flow sensor panels. Use of this power supply with these older air flow sensor panels may result in premature failure of the power supply.

Acceptable air flow sensor panels are identified with a star (☆) located on the corner of air flow sensor panel next to the plastic 3-pin connector. If the unit being serviced does not have the star on the air flow sensor panel, replace the air flow sensor panel with field service part number F859-0381.

Remove AC power from the air cleaner.

Remove required hardware to gain access to the power supply to be replaced.

Disconnect all leads from the power supply to be replaced. Remove old power supply by pulling back on the spring latch or removing screws (some models). Replace with new power supply.

Reconnect all leads to their appropriate terminals.

**Ensure that green ground lead is attached to the "GND" terminal before proceeding.**

Replace all hardware and apply power.

Refer to applicable air cleaner service literature to determine if the appliance is functioning properly.

## Operating Indicator

Some older electronic air cleaner models have a neon operating indicator. This indicator has a yellow wire attached to the power supply. The neon type indicator cannot be used with the new power supply. Drill 1/4" hole to mount LED indicator. F858-1002 replacement kit has the replacement LED indicator light. If LED light is required order F844-0130.

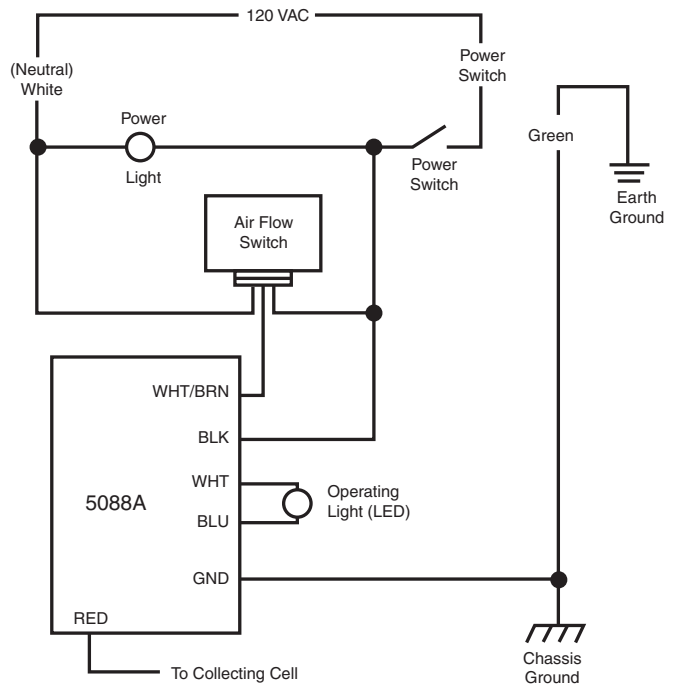

Figure 1. Typical System Wiring Diagram

## INSTALLATION - F858-1002 (cont'd)

### Air Flow Switch

Disconnect the 3-wire plastic plug from the 3-pin connector on the air flow switch.

Remove two mounting screws attaching the air flow switch circuit board to the back cover and remove board.

Remove the protective metal clip covering the thermistor on the new circuit board.

### NOTE

**To Avoid Damage To The Thermistor, The Board Should Be Handled With Care.**

Insert the two nylon screws through the new circuit board with the screw heads on the connector side of the board. Place the two nylon spacers over the screws on the thermistor side of the board.

Install new air flow switch with the thermistor positioned in the hole with the black bushings. Ensure that the two nylon screws with spacers pass through the two small holes in the back cover and the thermistor is centered in the black bushing. (See illustration).

Secure the assembly with two nuts on the nylon screws on the outside surface of back cover.

Reconnect the 3-wire plastic plug to the 3-pin connector.

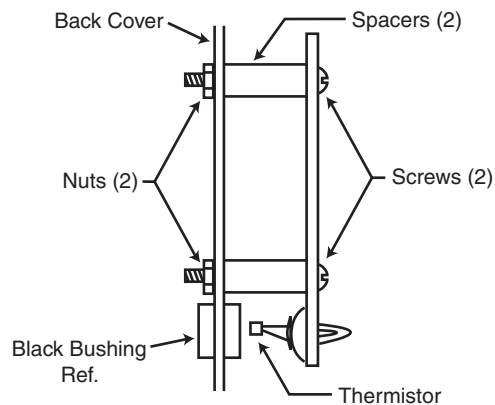
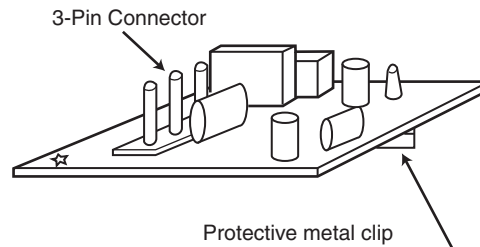

Figure 2. Air Flow Switch

## INSTALLATION - F859-0381

1. Remove AC power from the air cleaner.
2. Remove power pack from air cleaner cabinet.
3. Open the back panel at rear of power pack. Note: **Do Not Put Excessive Strain** on the red wire connected to Back Panel.
4. Disconnect the white wire that goes from power supply to the AC Power Plug. Cut off the quick connect terminal and strip 1/2" insulation from the end.
5. Locate the 3-wire connector and cut off the quick-connect terminal on the end of the white wire. Strip 1/2" insulation from the end. Splice this wire to the white wire in step 4 using the wire nut provided.
6. Connect the white/brown wire from the 3-wire connector to the open power supply terminal (Step 4).
7. Locate the black wire connecting the On/Off switch to the power supply. Disconnect this wire from the switch. **DO NOT DISCONNECT** the wire at the AC plug.
8. Install black wire from the 3-wire connector and black wire (open from Step 7) to open terminal at ON/OFF switch. The two wires must be piggy-backed together prior to installing.

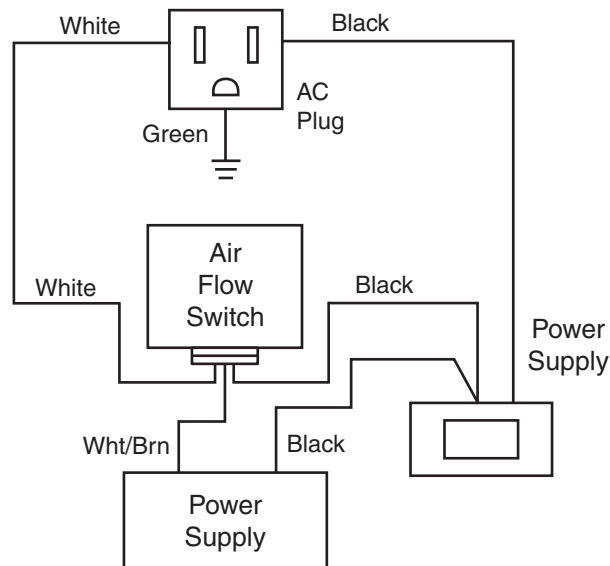

Figure 4

9. Remove the metal thermistor protector from the air flow monitor (Fig. 2).
10. Remove black hole plug from back panel and install the two bushings in 3/4" dia. hole from outside of back panel (Fig.2). Install larger bushing first, then the smaller bushing into the larger one.
11. Insert the two nylon screws through air flow monitor board (screw heads on connector side). Place the two spacers over the screws (thermistor side) then install air flow monitor the back panel with the two nuts provided. Note: The thermistor must be placed over and centered above the hole where the two bushings were installed
12. Connect the 3-pin connector to air flow monitor.
13. Reinstall back panel and replace power pack to cabinet.
14. Air cleaner and air handling system is ready to energized.

## OPERATION

### Ozone Reduction

The electronic air cleaners produce a small quantity of ozone that is within established limits. Some customers may notice an odor especially at high altitudes or low air flow rates.

The 5088A is equipped with a "hairpin" shaped jumper wire which can be cut and separated in case of such complaints. This will cause the control to limit the maximum operating power to a lower level.

Cutting the ozone reduction jumper should be done as a last resort since it will also somewhat lower the efficiency of the air cleaner

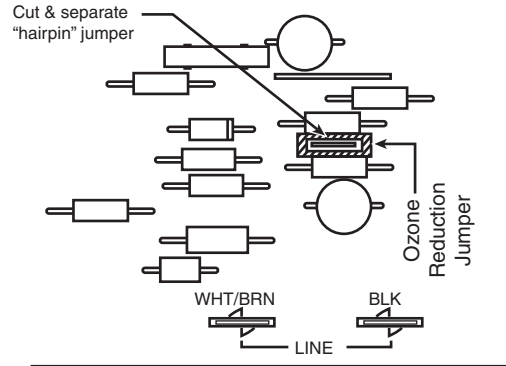

Figure 3. Ozone Reduction Jumper

## TROUBLESHOOTING

PROBLEM	CORRECTIVE ACTION
Radio or TV interference is present whenever air cleaner is operating.	<p>Check for proper grounding of appliance to 120 VAC service.</p> <p>Insure "GND" terminal of 5088A is connected to metal chassis.</p> <p>Insure spring contacts underneath 5088A are contacting chassis. Clean if necessary.</p>
Operating indicator does not light.	<p>Check for shorted cell.</p> <p>Air flow switch not operating.</p>
Cell arcs continuously.	<p>Dirty cell, bent collecting plate, loose ionizing wire, foreign object in cell.</p>
Cell does not clean the air	<p>Cell(s) installed backwards.</p> <p>Ionizing wires broken.</p>
Ozone odor	<p>Insure operating light goes out when blower stops (check air flow switch, vane switch, field wiring, etc.).</p> <p>Ensure blower is operating at proper CFM rate.</p> <p>Carefully cut and separate the ozone reduction jumper on the 5088A power supply.</p>