

# Residential Air Cleaners

## FUTURE OPTION . . .

### The Time Might Be Right To Upgrade

The F25F Media Air Cleaner cabinet and filter cartridge are designed to be easily upgraded to an F50F Electronic Air Cleaner. An electronic air cleaner has the features to increase the comfort and enjoyment of your customer's home.

- Up to 95 percent efficient at capturing airborne particles from the air that passes through it.
- Up to 30 times better at cleaning the air than typical furnace filters. (Based on initial dust spot efficiency, ASHRAE 52.1-92.)
- Can save 10 to 15 percent in operating costs over the life of the equipment. Honeywell offers an exclusive 10-year Clean Coil Guarantee.
- Protects investment in expensive HVAC equipment.
- No on-going filter replacements necessary because cells can be washed and restored to like-new efficiency.
- Increased home comfort.
- Easy to maintain.

### Upgrade in a few easy steps . . .

1. Start with a complete F50F. Remove F25F door.

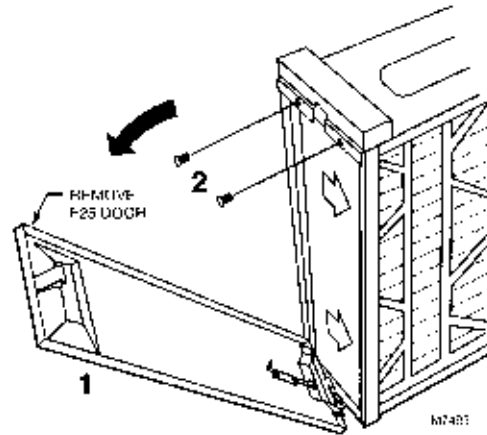

2. Remove and discard F25F filter cartridge; insert cell key, two cells and prefilters from the F50F.

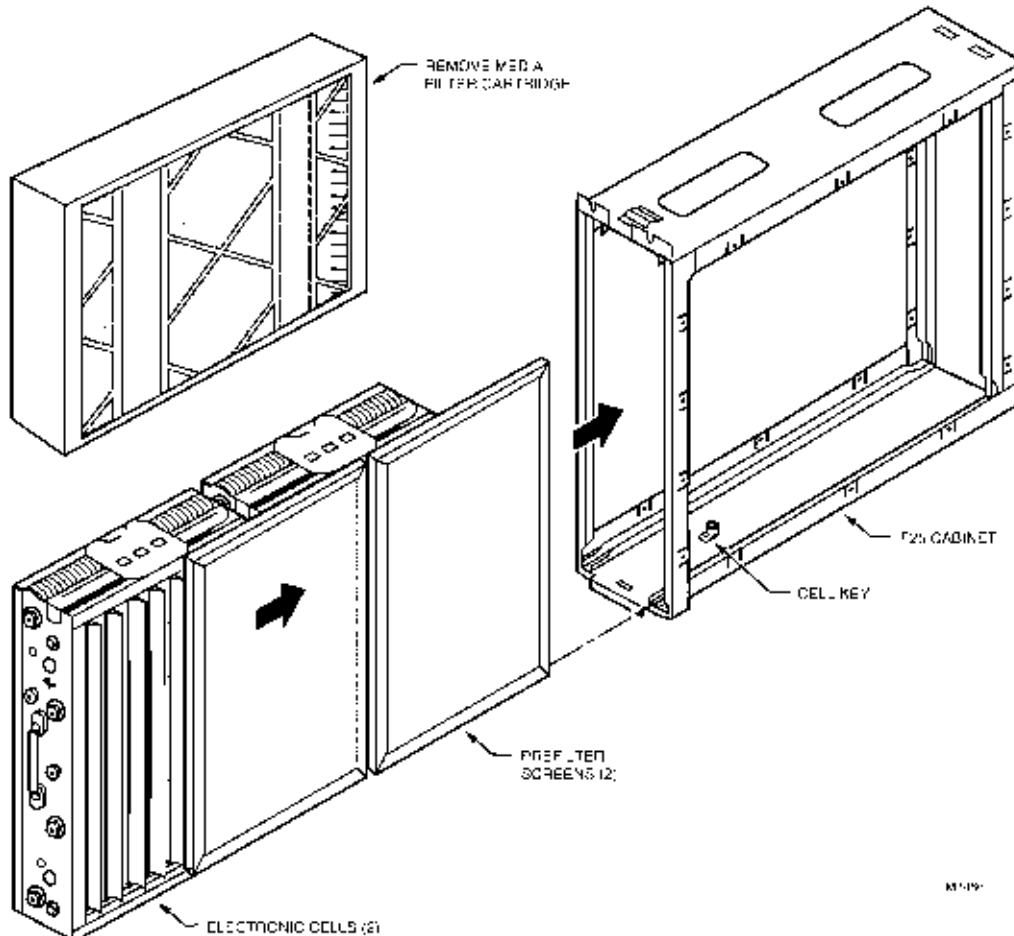

# Residential Air Cleaners

FUTURE OPTION . . . continued

3. Remove knockouts from top of cabinet. Install and plug in F50F power box.

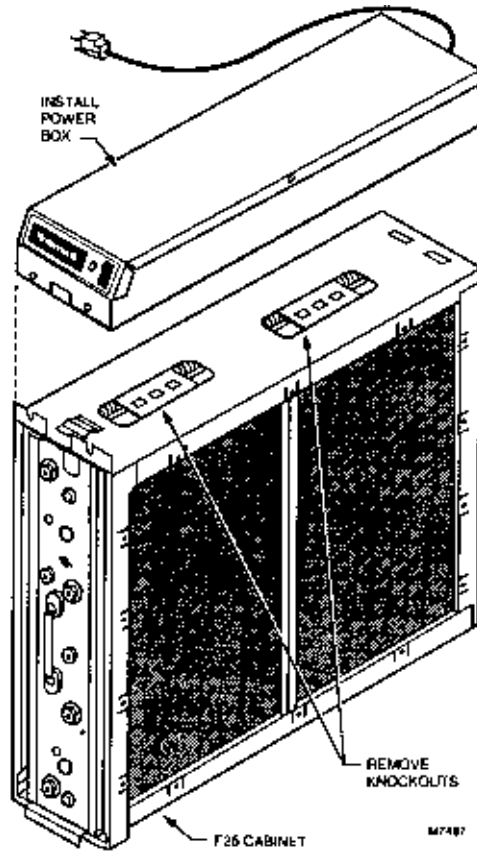

4. Install F50F door. Cover knockout holes in empty F50F cabinet with duct tape. Insert new F25F filter cartridge and install F25F door. Now you have another F25F for sale!

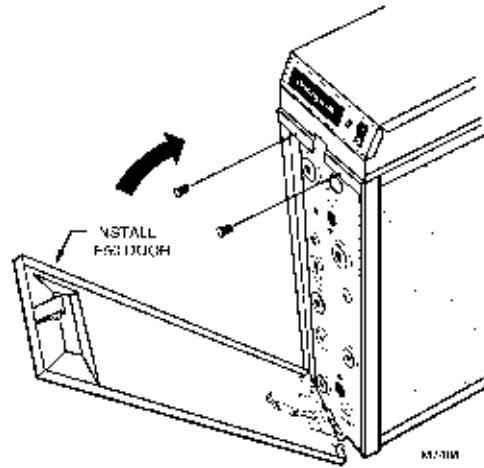

See page 216 for order numbers.