

C7046A,B,C,D Air Temperature Sensors

INSTALLATION INSTRUCTIONS

APPLICATION

The C7046 series of Air Temperature Sensors function as primary and/or secondary sensors in electronic control systems.

INSTALLATION

When Installing this Product...

1. Read these instructions carefully. Failure to follow them could damage the product or cause a hazardous condition.
2. Check the ratings given in the instructions and on the product to make sure the product is suitable for your application.
3. Installer must be a trained, experienced service technician.
4. After installation is complete, check out product operation as provided in these instructions.

CAUTION

Electrical Shock or Equipment Damage Hazard.
Can shock individuals or short equipment circuitry.
Disconnect power supply before installation.

The sensor assembly (see Fig. 1) consists of an aluminum sensor probe (element housed internally) with attached flange that can be mounted on a flat duct or plenum surface, or in a 2 in. by 4 in. (51 by 102 mm) junction box using two No. 8 screws. Connections to the sensor are made through two 6 in. (152 mm) leadwires.

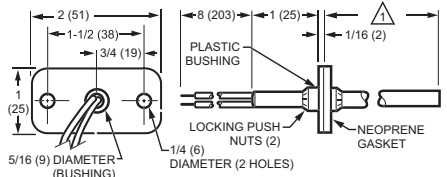

 INSERTION LENGTH DEPENDS UPON THE MODEL.

MZ2402A

Fig. 1. C7046A,B,C,D Air Temperature Sensor dimensions in in. (mm).

NOTE: Sensor probe diameter is 1/4 in. (6 mm).

Location

The sensor should be located in the air duct or plenum where it will sample an average air temperature. Avoid locations where air stratification can cause sensing errors.

Mounting

Mounting on Flat Duct or Plenum Surface (Fig. 2)

1. Cut a 3/8 in. (9.5 mm) hole in the duct or plenum surface at the desired location.
2. Insert sensor probe into the duct or plenum until the flange rests against the duct or plenum wall.
3. If necessary, use the flange as a template to mark and drill two holes for No. 8 mounting screws.
4. Fasten the sensor to the duct or plenum surface with two No. 8 sheet metal screws (not provided).

Mounting in a Junction Box (Fig. 3)

1. Cut a 3/8 in. (9.5 mm) hole in the duct or plenum surface at the desired location.
2. Remove the center rear knockout from the junction box and insert the sensing probe through the knockout with the flange flat against the outlet box.
3. Using the flange as a template, mark and drill two holes in the junction box and the duct or plenum surface for No. 8 mounting screws.
4. Insert sensor probe through both the junction box knockout and the 3/8 in. (9.5 mm) hole drilled in the duct or plenum and fasten the junction box and sensor to the duct or plenum surface.



⚠ CAUTION

Erratic System Operation Hazard.
Failure to follow proper wiring practices can introduce disruptive electrical interference (noise).

Keep wiring at least one foot away from large inductive loads such as motors line starters, lighting ballasts, and large power distribution panels.

Shielded cable is required in installations where these guidelines cannot be met.

Ground shield only to grounded controller case.

IMPORTANT

1. All wiring must agree with applicable codes, ordinances and regulations.
2. Do not mount sensor in incorrect environment.
3. Wire according to the applicable controller instructions.
4. Erratic temperature readings from a sensor can be caused by improper wiring practices. These must be avoided to assure proper operation:
 - Avoid poor wiring connections.
 - Avoid intermittent or missing building earth ground.
 - Do not mount sensor in incorrect environment.

Connect low voltage wiring from the sensor to the appropriate system component terminals using solderless connectors. See Fig. 3.

NOTES:

1. For connections to the W973 Single Zone Logic Panel, see Fig. 4.
2. For connections to the W7080 Multizone System, see Fig. 5.
3. For connections to the Excel 500 Control System, see Fig. 6.
4. For additional wiring information, refer to the appropriate specification.

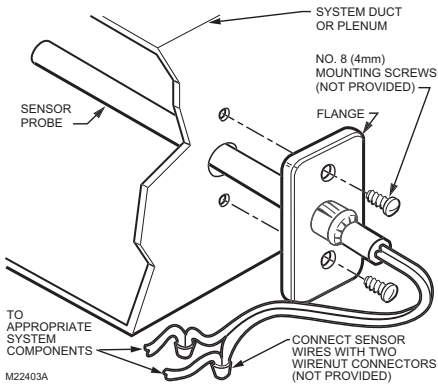

Fig. 2. Mounting C7046 Air Temperature Sensor on a flat duct or plenum surface.

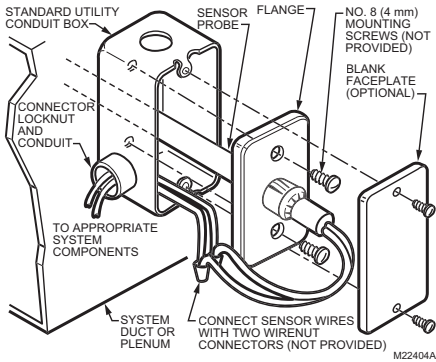

Fig. 3. Mounting C7046 Air Temperature Sensor in a junction box.

Wiring

⚠ CAUTION

Electrical Shock or Equipment Damage Hazard.

Can shock individuals or short equipment circuitry.

Disconnect power supply before installation.

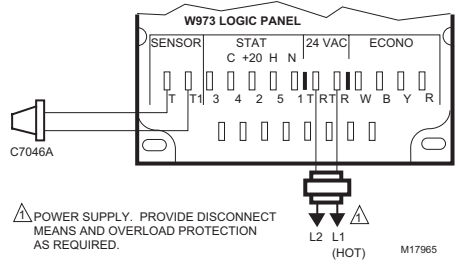

Fig. 4. Connecting C7046A Air Temperature Sensor to a W973 Single Zone Logic Panel.

OPERATION AND CHECKOUT

Operation

The C7046A,B,C Air Temperature Sensors consist of a thermistor sensing element mounted in a tubular probe. They are applied at various locations throughout single zone and multizone duct systems. The negative temperature coefficient (NTC) characteristic of the thermistor element causes its resistance to decrease as the sampled air temperature increases. This resistance shift is balanced with other system sensor signals by appropriate system logic panels to stabilize system control.

The C7046D Air Temperature Sensor consists of a platinum thin film sensor element mounted in a tubular probe. It can be applied at various locations throughout single zone and multizone duct systems. The positive temperature coefficient (PTC) characteristics of the platinum thin film element causes its resistance to increase as the sampled air temperature increases. This resistance shift is balanced with other system sensor signals by the Excel 500 Control System.

Checkout

Allow the C7046 Air Temperature Sensor to soak in the air moving through the duct or plenum for a minimum of five minutes before taking a resistance measurement.

1. Disconnect the sensor leadwires from the associated system components.
2. Connect an ohmmeter across the leadwires.
3. Assure nominal resistance measurements are in accordance with the resistance/temperature curves shown in Figs. 7, 8 and 9.
4. Reconnect sensor leadwires to associated system components.
5. Check operation of the complete control system.

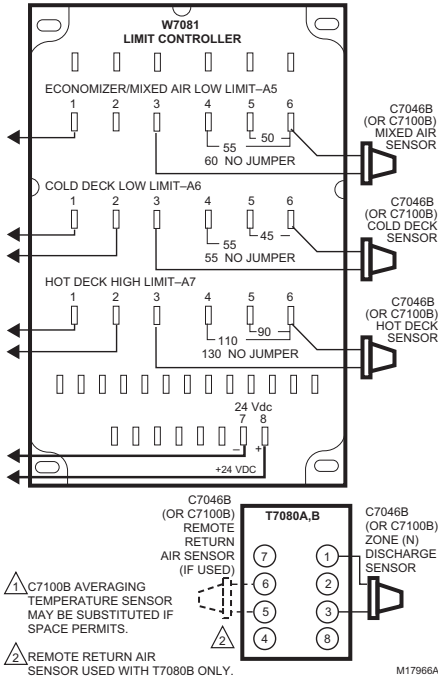

Fig. 5. Connecting C7046B Air Temperature Sensor for mixed air, cold deck and hot deck sensing, zone discharge and optional remote return air sensing in W7080 Multizone System.

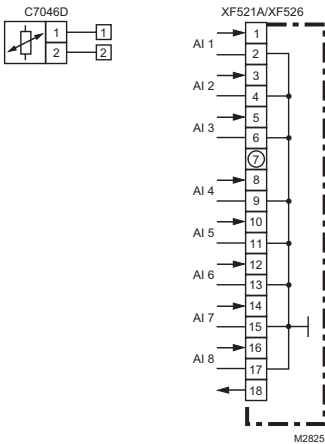

Fig. 6. Connecting C7046D Air Temperature Sensor to Excel 500 Control System.

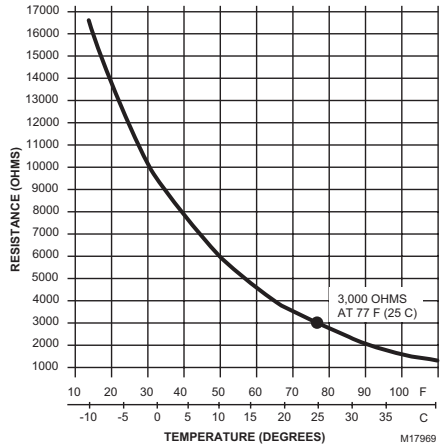

Fig. 7. C7046A,C Sensor resistance vs. temperature.

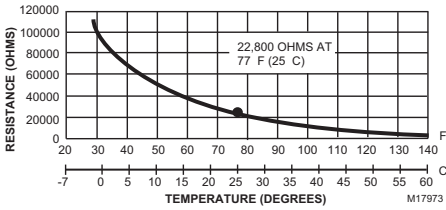

Fig. 8. C7046B Sensor resistance vs. temperature.

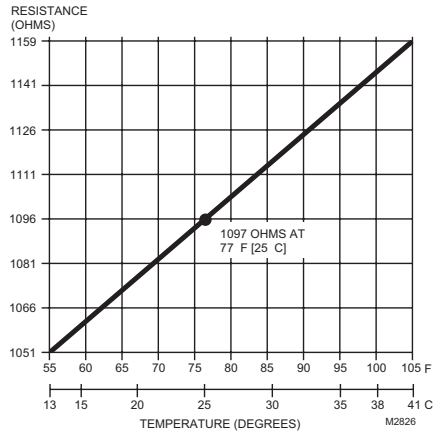

Fig. 9. C7046D Sensor resistance vs. temperature.

Honeywell

Automation and Control Solutions

Honeywell International Inc.
1985 Douglas Drive North
Golden Valley, MN 55422

Honeywell Limited-Honeywell Limitée
35 Dynamic Drive
Scarborough, Ontario
M1V 4Z9

