

VR8345M Universal Electronic Ignition Gas Control

The VR8345M Universal Electronic Ignition Gas Control is used in gas-fired appliances with capacities up to 300 cu ft/hour at 1 inch wc pressure drop [8.5 cu m/hour at 0.25 kPa] for natural gas. The VR8345M will operate with a direct spark ignition (DSI), hot surface ignition (HSI) or intermittent pilot ignition. The control includes a manual valve, two automatic operators, a pressure regulator, pilot adjustment, pilot plug, and ignition adapter.



- Compatible with hot surface pilot, intermittent pilot and direct spark ignition.
- Replaces virtually any IP, HSI or DSI gas control.
- For use with 24 Vac heating appliances that burn natural or manufactured gas or liquefied petroleum (LP) gas. (Includes converter kit to adapt from natural gas to LP gas.)
- Compact to fit into tightly packed, high efficiency heating equipment.
- Works with virtually all residential equipment and all but the largest commercial equipment, with a regulation capacity range of 30,000 to 415,000 Btuh natural gas (48,600 to 672,300 LP gas).
- All adjustments and wiring connections accessible from top of control.
- Straight-through body pattern.
- 1/8 in. NPT inlet and outlet taps on top of gas control aid adjustment of gas pressure in problem installations.
- 3/4 in. x 3/4 in. inlet and outlet fit easily on high capacity systems plus others using 1/2 in. reducer bushings.

- 4.0 in. swing radius allows easy rotation into position inside the tightest furnace vestibules.
- Can be installed at any angle including vertically between 0 and 90 degrees from the upright position.
- Clearly marked, keyed terminal block allows quick attachment of wires and IP/DSI/HSI jumper. Keyed jumper cannot be incorrectly inserted.
- Internal inlet screen blocks contaminants in gas line from entering valve.
- -40°F to +175°F (-40°C to +79°C) temperature range standard.
- Standard opening.

CONTENTS

Specifications	2
Ordering Information	2
Installation	3
Startup and Checkout	11
Maintenance	13
Operation	14
Service	17



Specifications

IMPORTANT: *The specifications given in this publication do not include normal manufacturing tolerances. Therefore, this unit may not exactly match the listed specification. Also, this product is tested and calibrated under closely controlled conditions, and some minor differences in performance can be expected if those conditions are changed.*

MODEL: VR8345M Universal Combination Gas Control.
 AMBIENT TEMPERATURE RANGE: -40° to +175°F
 (-40° to +79°C).

BODY PATTERN: Straight-through.
 REGULATOR TYPE: Standard opening.
 INLET X OUTLET SIZE: 3/4 x 3/4 inch.
 IGNITION ADAPTER: Configures VR8345M to operate with direct spark or hot surface ignition.
 ELECTRICAL RATINGS:
 Voltage and Frequency: 24 Vac, 60 Hz.
 Current Draw: 0.7A.
 CAPACITY: See Table 1.

Use conversion factors in Table 2 to convert capacities for other gases.

TABLE 1—GAS CAPACITY.

Size (Inlet x Outlet)	Capacity (at 1 inch wc pressure drop) ^a	Minimum Regulated Capacity	Maximum Regulated Capacity
3/4 x 3/4	300 feet ³ /hr (8.5 meter ³ /hr)	30 feet ³ /hr (0.8 meter ³ /hr)	415 feet ³ /hr (11.8 meter ³ /hr)

^a Capacity based on 1000 Btu/cu ft, 0.64 specific gravity natural gas at 1 in. wc pressure drop (37.3 MJ/cu m, 0.64 specific gravity natural gas at 0.25 kPa pressure drop).

TABLE 2—GAS CAPACITY CONVERSION FACTORS.

Gas	Specific Gravity	Multiply Listed Capacity By
Manufactured	0.60	0.516
Mixed	0.70	0.765
Propane	1.53	1.620

APPROVALS:

American Gas Association Design Certificate: L2025007.
 Canadian Gas Association Design Certificate: L2025007.

PIPE ADAPTERS: Includes two 3/4 to 1/2 inch NPT bushings and one 1/2 to 3/8 inch NPT bushing.

CROSS REFERENCE: See Table 3 for cross reference information.

Fig. 1—VR8345 dimensions in in. (mm).

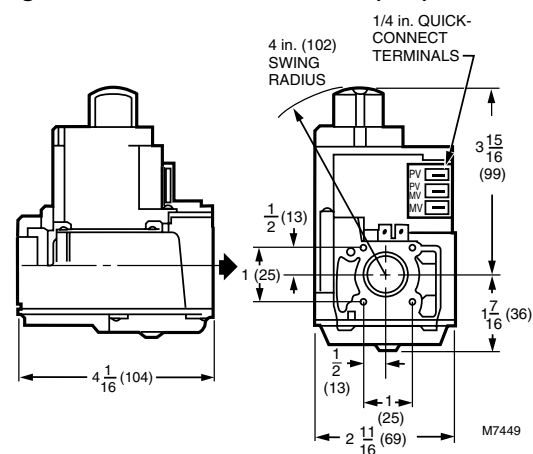

Ordering Information

When purchasing replacement and modernization products from your TRADELINE[®] wholesaler or distributor, refer to the TRADELINE[®] Catalog or price sheets for complete ordering number, or specify—

1. Order number.
2. Ordered separately; pilot burner, igniter-sensor, transformer, limit controller, and thermostat or controller as required.

If you have additional questions, need further information, or would like to comment on our products or services, please write or phone:

1. Your local Home and Building Control Sales Office (please check the white pages of your phone directory).
2. Home and Building Control Customer Logistics
 Honeywell Inc., 1885 Douglas Drive North
 Minneapolis, Minnesota 55422-4386 (612) 951-1000

In Canada—Honeywell Limited/Honeywell Limitée, 740 Ellesmere Road, Scarborough, Ontario M1P2V9. International Sales and Service Offices in all principal cities of the world. Manufacturing in Australia, Canada, Finland, France, Germany, Japan, Mexico, Netherlands, Spain, Taiwan, United Kingdom, U.S.A.

Installation

WHEN INSTALLING THIS PRODUCT...

1. Read these instructions carefully. Failure to follow them could damage the product or cause a hazardous condition.
2. Check the ratings given in the instructions and on the product to make sure the product is suitable for your application.
3. The installer must be a trained, experienced service technician.
4. After installation is complete, use these instructions to check out product operation.

IMPORTANT: *It is recommended that an appliance shutoff valve be installed upstream of the VR8435M.*



WARNING

**FIRE OR EXPLOSION HAZARD
CAN CAUSE PROPERTY DAMAGE,
SEVERE INJURY, OR DEATH**

Follow these warnings exactly:

1. Disconnect power supply before wiring to prevent electrical shock or equipment damage.
2. To avoid dangerous accumulation of fuel gas, turn off gas supply at the appliance service valve before starting installation, and perform Gas Leak Test after completing installation.
3. When working with a system using intermittent pilot ignition, do not bend pilot tubing at gas control or pilot burner after compression fitting has been tightened because gas leakage at the connection can result.
4. Always install sediment trap in gas supply line to prevent contamination of gas control.
5. Do not force the gas control knob. Use only your hand to turn the gas control knob. Never use any tools. If the gas control knob does not operate by hand, call a qualified service technician to replace the gas control. Force or attempted repair can result in fire or explosion.

TABLE 3—VR8345 REPLACES THESE GAS CONTROLS.

Old Model No.	Manufacturer	Replacement Gas Controls			Universal Replacement
		VR8200	VR8300	VR800	
36E36-304 DSI/HSI	WHITE RODGERS	VR8205A2024	VR8305M3506	VR8450A4113	VR8345M4302 ^a
36E36-304 IP	WHITE RODGERS	VR8204A2076	VR8304M3509	VR8440A3025	VR8345M4302
720-050	ROBERTSHAW	VR8205A2024	VR8305M3506	—	VR8345M4302 ^a
720-051	ROBERTSHAW	VR8205A2024	VR8305M3506	—	VR8345M4302 ^a
720-070	ROBERTSHAW	VR8204A2076	VR8304A3509	—	VR8345M4302
V4185A1000	HONEYWELL	VR8205A2024 ^b	VR8305M3506 ^b	VR8450A4113 ^b	VR8345M3402 ^{a,b}
V4185A1010	HONEYWELL	VR8205A2024 ^b	VR8305M3506 ^b	VR8450A4113 ^b	VR8345M4302 ^{a,b}
V4185B1008	HONEYWELL	VR8205A2024 ^b	VR8305M3506 ^b	VR8450A4113 ^b	VR8345M4302 ^{a,b}
V4185B1016	HONEYWELL	VR8205A2024 ^b	VR8305M3506 ^b	VR8450A4113 ^b	VR8345M4302 ^{a,b}
V4185B1024	HONEYWELL	VR8205A2024 ^b	VR8305M3506 ^b	VR8450A4113 ^b	VR8345M4302 ^{a,b}
V4225A1002	HONEYWELL	VR8205A2024 ^b	VR8305M3506 ^b	VR8450A4113 ^b	VR8345M4302 ^{a,b}
V4225A1028	HONEYWELL	VR8205A2024 ^b	VR8305M3506 ^b	VR8450A4113 ^b	VR8345M4302 ^{a,b}
V4225A1044	HONEYWELL	VR8205A2024 ^b	VR8305M3506 ^b	VR8450A4113 ^b	VR8345M4302 ^{a,b}
V4225A1051	HONEYWELL	VR8205A2024 ^b	VR8305M3506 ^b	VR8450A4113 ^b	VR8345M4302 ^{a,b}
V4225A1077	HONEYWELL	VR8205A2024 ^b	VR8305M3506 ^b	VR8450A4113 ^b	VR8345M4302 ^{a,b}
V4225B1000	HONEYWELL	VR8205A2024 ^b	VR8305M3506 ^b	VR8450A4113 ^b	VR8345M4302 ^{a,b}
V4225B1018	HONEYWELL	VR8205A2024 ^b	VR8305M3506 ^b	VR8450A4113 ^b	VR8345M4302 ^{a,b}
V4225B1026	HONEYWELL	VR8205A2024 ^b	VR8305M3506 ^b	VR8450A4113 ^b	VR8345M4302 ^{a,b}

(Footnotes at end of table).

(Continued)

TABLE 3—VR8345 REPLACES THESE GAS CONTROLS (Continued).

Old Model No.	Manufacturer	Replacement Gas Controls			Universal Replacement
		VR8200	VR8300	VR800	
V4227A1000	HONEYWELL	VR8205A2024 ^b	VR8305M3506 ^b	VR8450A4113 ^b	VR8345M4302 ^{a,b}
V4227A1018	HONEYWELL	VR8205A2024 ^b	VR8305M3506 ^b	VR8450A4113 ^b	VR8345M4302 ^{a,b}
V4227B1008	HONEYWELL	VR8205A2024 ^b	VR8305M3506 ^b	VR8450A4113 ^b	VR8345M4302 ^{a,b}
V4227B1016	HONEYWELL	VR8205A2024 ^b	VR8305M3506 ^b	VR8450A4113 ^b	VR8345M4302 ^{a,b}
V4249A1004	HONEYWELL	VR8205A2024 ^b	VR8305M3506 ^b	VR8450A4113 ^b	VR8345M4302 ^{a,b}
V4249A1012	HONEYWELL	VR8205A2024 ^b	VR8305M3506 ^b	VR8450A4113 ^b	VR8345M4302 ^{a,b}
V4249A1020	HONEYWELL	VR8205A2024 ^b	VR8305M3506 ^b	VR8450A4113 ^b	VR8345M4302 ^{a,b}
V4297A1005	HONEYWELL	VR8205A2024 ^b	VR8305M3506 ^b	VR8450A4113 ^b	VR8345M4302 ^{a,b}
V4297A1013	HONEYWELL	VR8205A2024 ^b	VR8305M3506 ^b	VR8450A4113 ^b	VR8345M4302 ^{a,b}
V4297A1021	HONEYWELL	VR8205A2024 ^b	VR8305M3506 ^b	VR8450A4113 ^b	VR8345M4302 ^{a,b}
V4297A1039	HONEYWELL	VR8205A2024 ^b	VR8305M3506 ^b	VR8450A4113 ^b	VR8345M4302 ^{a,b}
V4297A1047	HONEYWELL	VR8205A2024 ^b	VR8305M3506 ^b	VR8450A4113 ^b	VR8345M4302 ^{a,b}
V4297A1054	HONEYWELL	VR8205A2024 ^b	VR8305M3506 ^b	VR8450A4113 ^b	VR8345M4302 ^{a,b}
V4298A1004	HONEYWELL	VR8205A2024 ^b	VR8305M3506 ^b	VR8450A4113 ^b	VR8345M4302 ^{a,b}
V4298A1012	HONEYWELL	VR8205A2024 ^b	VR8305M3506 ^b	VR8450A4113 ^b	VR8345M4302 ^{a,b}
V445A1009	HONEYWELL	VR8205A2024 ^b	VR8305M3506 ^b	VR8450A4113 ^b	VR8345M4302 ^{a,b}
V445A1017	HONEYWELL	VR8205A2024	VR8305M3506 ^b	VR8450A4113 ^b	VR8345M4302 ^{a,b}
V8185A1001	HONEYWELL	VR8205A2024	VR8305M3506	VR8450A4113	VR8345M4302 ^a
V8185A1019	HONEYWELL	VR8205A2024	VR8305M3506	VR8450A4113	VR8345M4302 ^a
V8185A1035	HONEYWELL	VR8205A2024	VR8305M3506	VR8450A4113	VR8345M4302 ^a
V8185B1009	HONEYWELL	VR8205A2024	VR8305M3506	VR8450A4113	VR8345M4302 ^a
V8185B1017	HONEYWELL	VR8205A2024	VR8305M3506	VR8450A4113	VR8345M4302 ^a
V8247A1000	HONEYWELL	VR8205A2024	VR8305A3506	VR8450A4113	VR8345M4302 ^a
V8247B1005	HONEYWELL	VR8205A2024	VR8305A3506	VR8450A4113	VR8345M4302 ^a
V845A1018	HONEYWELL	VR8205A2024	VR8305A3506	VR8450A4113	VR8345M4302 ^a
V845A1026	HONEYWELL	VR8205A2024 ^c	VR8305A3506	VR8450A4113 ^c	VR8345M4302 ^{a,c}
V845A1034 ^d	HONEYWELL	VR8205A2024	VR8305A3506	VR8450A4113	VR8345M4302 ^a
V845A1133 ^d	HONEYWELL	VR8205A2024	VR8305A3506	VR8450A4113	VR8345M4302 ^a
VR4450M2035	HONEYWELL	VR8205A2024 ^b	VR8305A3506 ^b	VR8450A4113 ^b	VR8345M4302 ^{a,b}
VR4450M2126	HONEYWELL	VR8205A2024 ^b	VR8305A3506 ^b	VR8450A4113 ^b	VR8345M4302 ^{a,b}
VR4450M2159 ^d	HONEYWELL	VR8205A2024 ^b	VR8305M3506 ^b	VR8450A4113 ^b	VR8345M4302 ^{a,b}
VR445M1009	HONEYWELL	VR8205A2024 ^b	VR8305M3506 ^b	VR8450A4113 ^b	VR8345M4302 ^{a,b}
VR445M1017 ^d	HONEYWELL	VR8205A2024 ^{b,c}	VR8305M3506 ^{b,c}	VR8450A4113 ^{b,c}	VR8345M4302 ^{a,b,c}
VR8204A2032	HONEYWELL	—	—	—	VR8345M4302
VR8204A2001	HONEYWELL	VR8204A2076	—	—	VR8345M4302
VR8204A2027	HONEYWELL	VR8204A2076 ^c	—	—	VR8345M4302 ^c
VR8204A2035	HONEYWELL	VR8204A2076 ^c	—	—	VR8345M4302 ^c
VR8204A2043 ^d	HONEYWELL	VR8204A2076 ^c	—	—	VR8345M4302 ^c
VR8204A2050	HONEYWELL	VR8204A2076	—	—	VR8345M4302
VR8204A2068 ^d	HONEYWELL	VR8204A2076	—	—	VR8345M4302
VR8204A2076	HONEYWELL	VR8204A2076	—	—	VR8345M4302

(Footnotes at end of table).

(Continued)

TABLE 3—VR8345 REPLACES THESE GAS CONTROLS (Continued).

Old Model No.	Manufacturer	Replacement Gas Controls			Universal Replacement
		VR8200	VR8300	VR800	
VR8204A2092 ^d	HONEYWELL	VR8204A2076 ^c	—	—	VR8345M4302 ^c
VR8204A2100	HONEYWELL	VR8204A2076 ^e	—	—	VR8345M4302 ^e
VR8204A2118	HONEYWELL	VR8204A2076 ^{e,f}	—	—	VR8345M4302 ^{e,f}
VR8204A2126	HONEYWELL	VR8204A2076	—	—	VR8345M4302
VR8204A2134	HONEYWELL	VR8204A2076 ^c	—	—	VR8345M4302 ^c
VR8204A2142	HONEYWELL	VR8204A2076	—	—	VR8345M4302
VR8204A2167 ^d	HONEYWELL	VR8204A2076 ^c	—	—	VR8345M4302 ^c
VR8204A2175	HONEYWELL	VR8204A2076 ^c	—	—	VR8345M4302 ^c
VR8205A2008	HONEYWELL	VR8205A2024	—	—	VR8345M4302 ^a
VR8205A2016 ^d	HONEYWELL	VR8205A2024 ^c	—	—	VR8345M4302 ^{a,c}
VR8205A2024	HONEYWELL	VR8205A2024	—	—	VR8345M4302 ^a
VR8205A2073	HONEYWELL	VR8205A2024 ^e	—	—	VR8345M4302 ^{a,c}
VR8440A2001	HONEYWELL	VR8204A2076	VR8304M3509	VR8440A3025	VR8345M4302
VR8440A2019 ^d	HONEYWELL	VR8204A2076	VR8304M3509	VR8440A3025	VR8345M4302
VR8440A2050	HONEYWELL	VR8204A2076 ^c	VR8304M3509	VR8440A3025 ^c	VR8345M4302 ^c
VR8440A2076	HONEYWELL	VR8204A2076 ^c	VR8304M3509	VR8440A3025 ^c	VR8345M4302 ^c
VR8440A2084	HONEYWELL	VR8204A2076 ^c	VR8304M3509	VR8440A3025 ^c	VR8345M4302 ^c
VR8440A2092	HONEYWELL	VR8204A2076	VR8304M3509	VR8440A3025	VR8345M4302
VR8440A2100	HONEYWELL	VR8204A2076	VR8304M3509	VR8440A3025	VR8345M4302
VR8440A2118	HONEYWELL	VR8204A2076 ^e	VR8304M3509	VR8440A3025 ^e	VR8345M4302 ^e
VR8440A2134	HONEYWELL	VR8204A2076 ^c	VR8304M3509	VR8440A3025 ^c	VR8345M4302 ^c
VR8440A2142	HONEYWELL	VR8204A2076	VR8304M3509	VR8440A3025	VR8345M4302
VR8440M1000	HONEYWELL	VR8204A2076	VR8304M3509	VR8440A3025	VR8345M4302
VR8440M2008	HONEYWELL	VR8204A2076	VR8304M3509	VR8440A3025	VR8345M4302
VR8440M2016	HONEYWELL	VR8204A2076 ^c	VR8304M3509	VR8440A3025 ^c	VR8345M4302 ^c
VR8440M2024	HONEYWELL	VR8204A2076	VR8304M3509	VR8440A3025	VR8345M4302
VR8440M2032 ^d	HONEYWELL	VR8204A2076	VR8304M3509	VR8440A3025	VR8345M4302
VR8440M2040 ^d	HONEYWELL	VR8204A2076 ^c	VR8304M3509	VR8440A3025 ^c	VR8345M4302 ^c
VR8440M2057	HONEYWELL	VR8204A2076	VR8304M3509	VR8440A3025	VR8345M4302
VR8440M2065	HONEYWELL	VR8204A2076 ^c	VR8304M3509	VR8440A3025 ^c	VR8345M4302 ^c
VR8440M2073	HONEYWELL	VR8204A2076	VR8304M3509	VR8440A3025	VR8345M4302
VR8440M2081 ^d	HONEYWELL	VR8204A2076 ^c	VR8304M3509	VR8440A3025 ^c	VR8345M4302 ^c
VR8440M2099	HONEYWELL	VR8204A2076 ^c	VR8304M3509	VR8440A3025 ^c	VR8345M4302 ^c
VR844A1002	HONEYWELL	VR8204A2076	VR8304M3509	VR8440A3025	VR8345M4302
VR844A1028 ^d	HONEYWELL	VR8204A2076 ^c	VR8304M3509	VR8440A3025 ^c	VR8345M4302 ^c
VR844A1051	HONEYWELL	VR8204A2076	VR8304M3509	VR8440A3025	VR8345M4302
VR844A1085	HONEYWELL	VR8204A2076	VR8304M3509	VR8440A3025	VR8345M4302
VR844M1006	HONEYWELL	VR8204A2076	VR8304M3509	VR8440A3025	VR8345M4302
VR844M1014	HONEYWELL	VR8204A2076	VR8304M3509	VR8440A3025	VR8345M4302
VR844M1063	HONEYWELL	VR8204A2076	VR8304M3509	VR8440A3025	VR8345M4302
VR844M1162	HONEYWELL	VR8204A2076	VR8304M3509	VR8440A3025	VR8345M4302

(Footnotes at end of table).

(Continued)

TABLE 3—VR8345 REPLACES THESE GAS CONTROLS (*Continued*).

Old Model No.	Manufacturer	Replacement Gas Controls			Universal Replacement
		VR8200	VR8300	VR800	
VR844M1170	HONEYWELL	VR8204A2076	VR8304M3509	VR8440A3025	VR8345M4302
VR844M1188 ^d	HONEYWELL	VR8204A2076 ^c	VR8304M3509	VR8440A3025 ^c	VR8345M4302 ^c
VR844M1196 ^d	HONEYWELL	VR8204A2076 ^c	VR8304M3509	VR8440A3025 ^c	VR8345M4302 ^c
VR844M1220 ^d	HONEYWELL	VR8204A2076	VR8304M3509	VR8440A3025	VR8345M4302
VR844M1246	HONEYWELL	VR8204A2076	VR8304M3509	VR8440A3025	VR8345M4302
VR844M1287 ^d	HONEYWELL	VR8204A2076 ^c	VR8304M3509	VR8440A3025 ^c	VR8345M4302 ^c
VR844M1295	HONEYWELL	VR8204A2076 ^c	VR8304M3509	VR8440A3025 ^c	VR8345M4302 ^c
VR844N1003	HONEYWELL	VR8204A2076	VR8304M3509	VR8440A3025	VR8345M4302
VR844R1005 ^d	HONEYWELL	VR8204A2076 ^c	VR8304M3509	VR8440A3025 ^c	VR8345M4302 ^c
VR8450A2000	HONEYWELL	VR8205A2024	VR8305M3506	VR8450A4113	VR8345M4302
VR8450A2109	HONEYWELL	VR8205A2024	VR8305M3506	VR8450A4113	VR8345M4302 ^a
VR8450A2117 ^d	HONEYWELL	VR8205A2024	VR8305M3506	VR8450A4113	VR8345M4302 ^a
VR8450M2023	HONEYWELL	VR8205A2024	VR8305M3506	VR8450A4113	VR8345M4302 ^a
VR8450M2064	HONEYWELL	VR8205A2024	VR8305M3506	VR8450A4113	VR8345M4302 ^a
VR8450R6003	HONEYWELL	VR8205A2024	VR8305M3506	VR8450A4113	VR8345M4302 ^a
VR845M1013	HONEYWELL	VR8205A2024	VR8305M3506	VR8450A4113	VR8345M4302 ^a

^a Direct ignition application.

^b Requires Honeywell AT40 or AT72 transformer.

^c Regulator setting on replacement valve differs from original. Adjust to rated pressure as necessary for optimum performance.

^d Shipped by Honeywell as LP gas only; may have been converted to natural gas by OEM.

^e Use with 1/8 in. compression fitting, part no. 3934014-1.

^f Use with 3/4 in. angle flange, part no. 393690-15.

^g Requires 1/2 in. straight flange (part no. 393690—16) or an angle flange (part no. 393690—13).



CAUTION

Never apply a jumper across or short the valve coil terminals. This can burn out the heat anticipator in the thermostat or damage the electronic intermittent pilot (IP) module.

IMPORTANT: *These gas controls are shipped with protective seals over inlet and outlet tappings. Do not remove seals until ready to connect piping.*

Follow the appliance manufacturer instructions if available; otherwise, use the following instructions.

CONVERT BETWEEN NATURAL AND LP GAS



WARNING

**FIRE OR EXPLOSION HAZARD
 CAN CAUSE PROPERTY DAMAGE,
 SEVERE INJURY, OR DEATH**

Do not attempt to use a gas control set for natural gas on LP gas or a gas control set for LP gas on natural gas.

Convert standard-opening gas controls from natural gas to LP gas with the conversion kit included with this TRADELINE® gas control. Part number 393691 converts from natural to LP gas. Part number 394588 converts from LP to natural gas.

USE PIPE ADAPTER TO SOLVE SWING RADIUS PROBLEMS

In some field service applications, space limitations make it difficult or impossible to thread the gas control onto the gas supply pipe. This problem can be resolved for many installations by using a pipe adapter. Install the pipe adapter on the end of the supply pipe in place of the gas control by following the same precautions and instructions that are used for installing the gas control. After the pipe adapter is installed, attach the gas control to the adapter as outlined in the Install Pipe Adapter to Gas Control section.

NOTE: Using a pipe adapter increases the overall length of the gas control.

INSTALL PIPE ADAPTER TO GAS CONTROL

Install adapter to gas control as follows:

Bushings

1. Remove seal over gas control inlet or outlet.
2. Apply moderate amount of good quality pipe compound to bushing, leaving two end threads bare. See Fig. 2.
3. Insert bushing in gas control and carefully thread pipe into the bushing until tight.

Fig. 2—Use moderate amount of pipe compound.

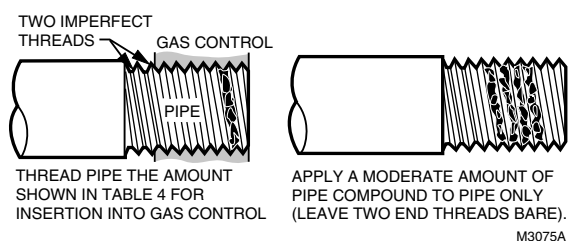

LOCATION

Locate the combination gas control in the appliance vestibule on the gas manifold. In replacement applications, locate the gas control in the same location as the old control.

Do not locate the gas control where it can be affected by steam cleaning, high humidity, dripping water, corrosive chemicals, dust or grease accumulation, or excessive heat.

For proper operation, follow these guidelines:

- Locate gas control in a well-ventilated area.
- Mount gas control high enough above the cabinet bottom to avoid exposure to flooding or splashing water.
- Make sure the ambient temperature does not exceed the ambient temperature ratings for each component.
- Cover gas control when the appliance is cleaned with water, steam, or chemicals or to avoid dust and grease accumulation.
- Avoid locating gas control where exposure to corrosive chemical fumes or dripping water is possible.

INSTALL PIPING TO GAS CONTROL

All piping must comply with applicable codes and ordinances or with the National Fuel Gas Code (ANSI Z223.1 NFPA No. 54), whichever applies. Tubing installation must comply with approved standards and practices.

1. Use new, properly reamed pipe free from chips. If tubing is used, make sure the ends are square, deburred and clean. Make sure all tubing bends are smooth and without deformation.

2. Run pipe or tubing to the gas control. If tubing is used, obtain a tube-to-pipe coupling to connect the tubing to the gas control.

3. Install sediment trap in the supply line to the gas control. See Fig. 3.

INSTALL GAS CONTROL

1. This gas control can be mounted from 0 to 90 degrees in any direction from the vertical position of the gas control knob.

2. Mount the gas control so gas flow is in the direction of the arrow on the bottom of the gas control.

3. Thread pipe the amount shown in Table 4 for insertion into the gas control.

TABLE 4—NPT PIPE THREAD LENGTH IN INCHES.

Pipe Size	Thread Pipe This Amount	Maximum Depth Pipe can be Inserted into Control
3/8	9/16	3/8
1/2	3/4	1/2
3/4	13/16	3/4

IMPORTANT: Do not thread pipe too far. Valve distortion or malfunction can result when the pipe is inserted too deeply into the gas control.

Fig. 3—Install sediment trap.

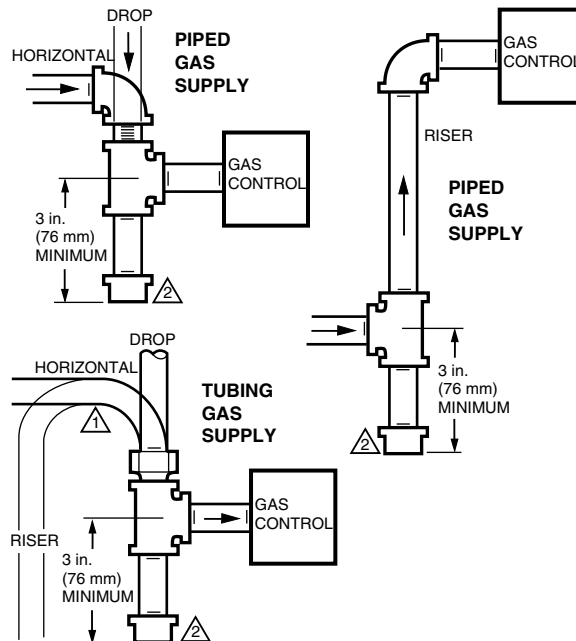

⚠ ALL BENDS IN METALLIC TUBING SHOULD BE SMOOTH.

⚠ **CAUTION: SHUT OFF THE MAIN GAS SUPPLY BEFORE REMOVING END CAP TO PREVENT GAS FROM FILLING THE WORK AREA. TEST FOR GAS LEAKAGE WHEN INSTALLATION IS COMPLETE.**

M8435

4. Apply a moderate amount of good quality pipe compound (do not use Teflon tape) to pipe only, leaving two end threads bare. See Fig. 2. On LP installations, use compound resistant to LP gas.

5. Remove seals over gas control inlet and outlet if necessary.

6. Connect pipe to gas control inlet and outlet. Use wrench on the square ends of the gas control. See Fig. 4 and 5.

When working with an intermittent pilot ignition system, go next to the Connect Pilot Gas Tubing section. When installing on a hot surface or direct spark ignition system, go to the Wiring section.

Fig. 4—Top view of gas control.

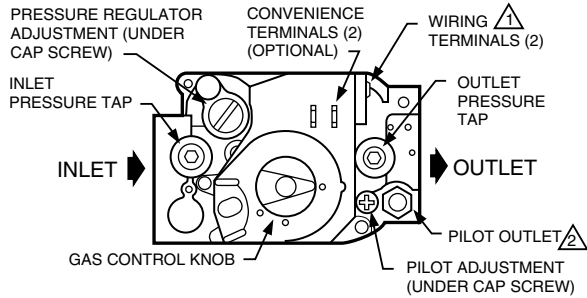

⚠ MUST USE WIRE ADAPTER (NOT SHOWN) ON HSI OR DSI SYSTEM.

⚠ MUST USE PILOT PLUG (NOT SHOWN) ON HSI OR DSI SYSTEM. M8436

Fig. 5—Proper use of wrench on gas control.

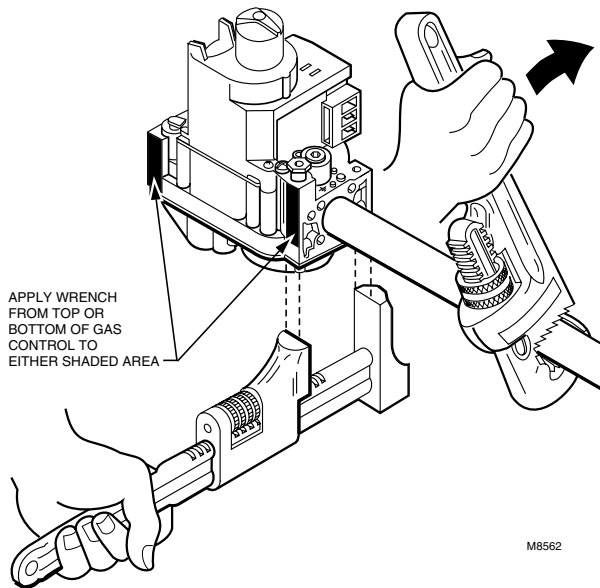

APPLY WRENCH FROM TOP OR BOTTOM OF GAS CONTROL TO EITHER SHADED AREA

M8562

CONNECT PILOT GAS TUBING (INTERMITTENT PILOT IGNITION ONLY)

1. Remove the pilot gas seal (plug).
2. Cut tubing to desired length and bend as necessary for routing to pilot burner.

! CAUTION

1. Do not make sharp bends or deform the tubing.
2. Do not bend tubing at the gas control or pilot burner after compression fitting has been tightened because this can result in gas leakage at the connection.

3. Square off and remove burrs from end of tubing.
4. Use the compression fitting supplied with this gas control. Slip the fitting over the tubing and slide out of the way.

NOTE: When replacing a gas control, cut off old compression fitting and replace with the new compression fitting provided on the gas control. Never use the old compression fitting because it may not provide a gas-tight seal.

5. Push tubing into the pilot gas tapping on the outlet end of the control until it bottoms. While holding tubing all the way in, slide compression fitting into place, engage threads and turn until finger tight. Then tighten one more turn with wrench. Do not overtighten. Refer to Figs. 6 and 7.

6. Connect other end of tubing to pilot burner according to pilot burner manufacturer instructions.

Fig. 6—Always use new compression fitting.

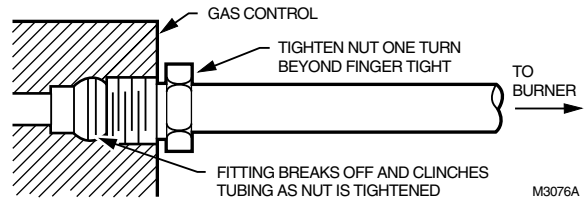
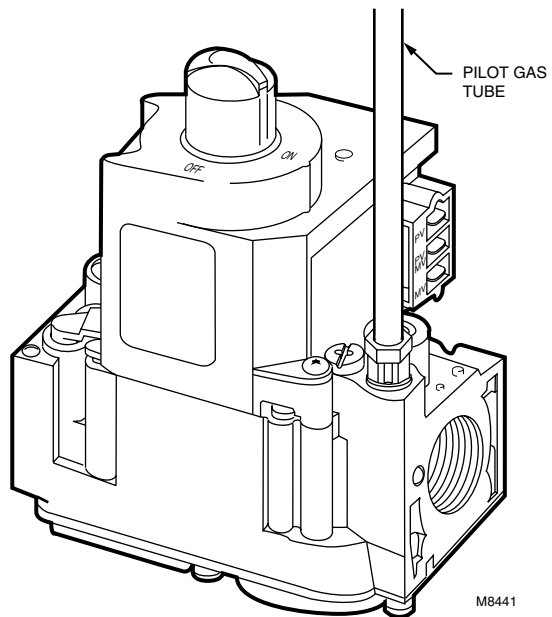

Fig. 7—Remove pilot gas seal (plug) and install pilot gas tube for intermittent pilot application on VR8345.



WIRING



CAUTION

Disconnect power supply before making wiring connections to prevent electrical shock or equipment damage.

Follow the wiring instructions furnished by the appliance manufacturer, if available, or use the following general instructions. Where these instructions differ from the appliance manufacturer, follow the appliance manufacturer instructions.

All wiring, including insulated quick connect terminals, must comply with applicable electrical codes and ordinances.

1. Check the power supply rating on the gas control and make sure it matches the available supply. Install thermostat and other controls as required.
2. When the gas control is installed on a hot surface or direct spark ignition system, attach the wire adapter provided to the wiring terminals. See Fig. 8 for the wire terminal location.
3. Connect control circuit to gas control terminals. See Figs. 4 and 9 through 11.
4. Adjust the thermostat heat anticipator to 0.7, the rating stamped on the valve operator.

Fig. 8—Install wire adapter for hot surface or direct spark ignition systems. Pilot plug must be in the valve pilot opening.

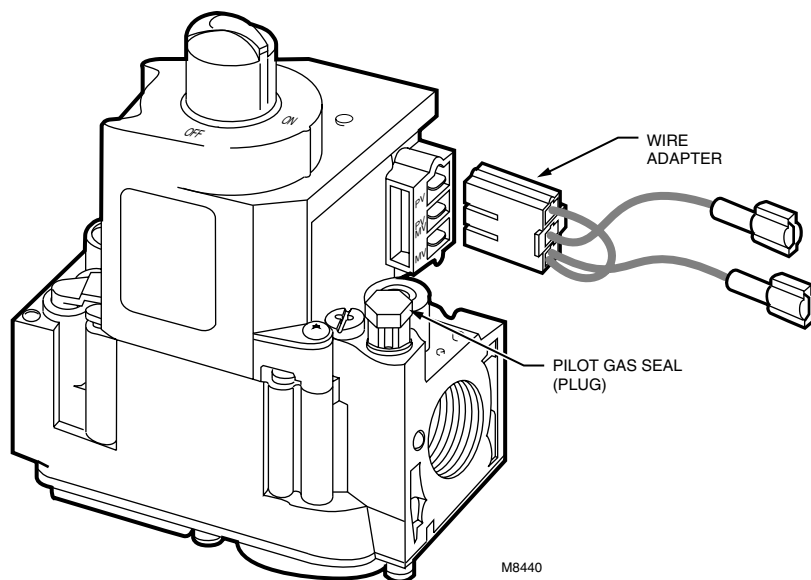
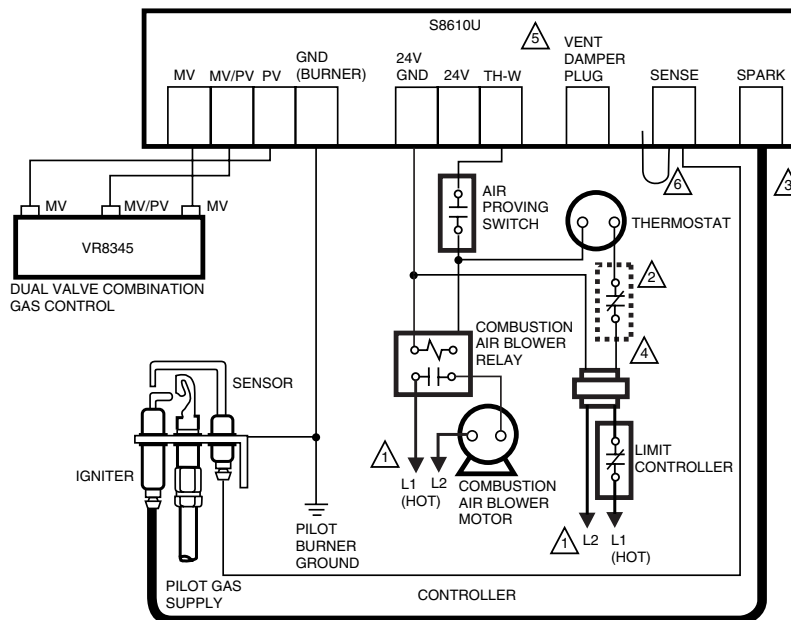
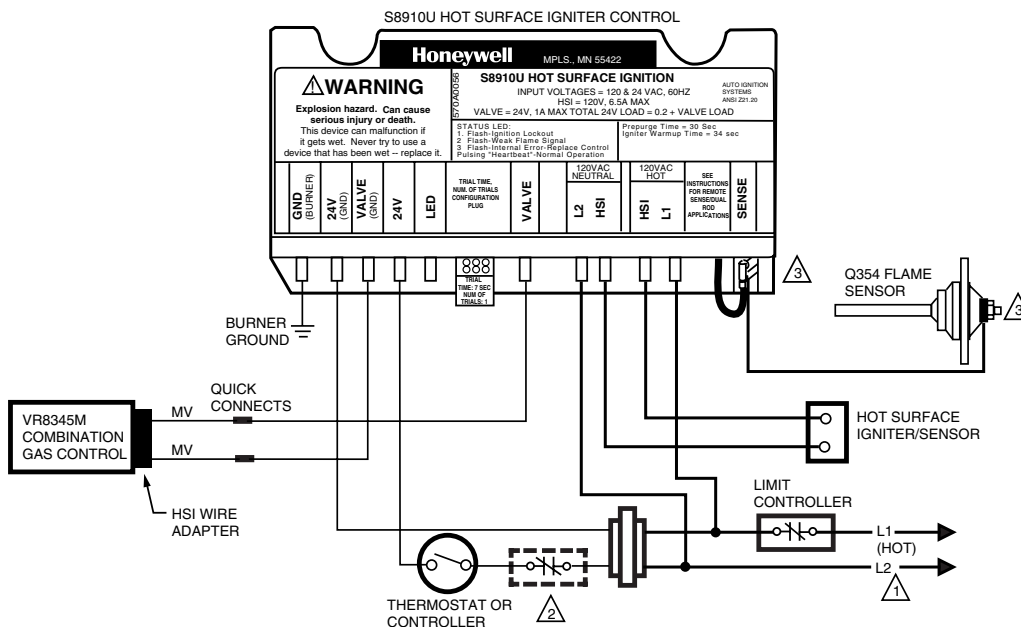

Fig. 9—VR8345 wiring connections in intermittent ignition system.



- ⚠ POWER SUPPLY. PROVIDE DISCONNECT MEANS AND OVERLOAD PROTECTION AS REQUIRED.
- ⚠ ALTERNATE LIMIT CONTROLLER LOCATION.
- ⚠ MAXIMUM CABLE LENGTH 3 ft [0.9 m].
- ⚠ CONTROLS IN 24V CIRCUIT MUST NOT BE GROUND LEG TO TRANSFORMER.
- ⚠ LEAVE VENT DAMPER PLUG CONNECTED.
- ⚠ REMOVE JUMPER AND CONNECT SENSE TERMINAL ON TWO ROD APPLICATION ONLY. M8564

Fig. 10—VR8345M wiring connections in hot surface ignition system.



- ⚠ POWER SUPPLY. PROVIDE DISCONNECT MEANS AND OVERLOAD PROTECTION AS REQUIRED. MAKE SURE L1 AND L2 ARE NOT REVERSED. THIS WOULD PREVENT FLAME DETECTION.
- ⚠ ALTERNATE LIMIT CONTROLLER LOCATION
- ⚠ SENSE TERMINAL AND Q354 FLAME SENSOR ON D MODELS ONLY. M8563

Fig. 11—VR8345 wiring connections in direct spark ignition system (single rod application).

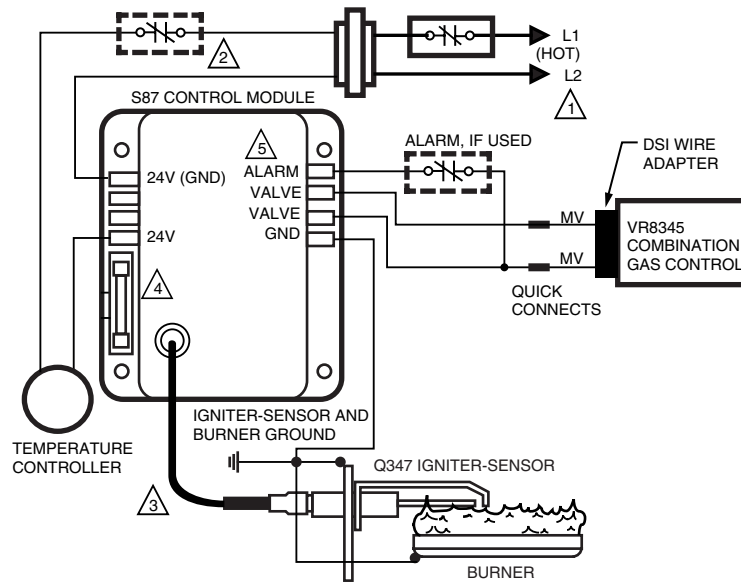

- ① POWER SUPPLY. PROVIDE DISCONNECT MEANS AND OVERLOAD PROTECTION AS REQUIRED.
- ② ALTERNATE LIMIT CONTROLLER LOCATION.
- ③ MAXIMUM IGNITER-SENSOR CABLE LENGTH: 3 ft [9 m] OR LESS.
- ④ 3A REPLACEABLE FUSE.
- ⑤ ALARM TERMINAL PROVIDED ON SOME MODELS.

M8438

Startup and Checkout



WARNING

**FIRE OR EXPLOSION HAZARD
 CAN CAUSE PROPERTY DAMAGE,
 SEVERE INJURY, OR DEATH**

1. Do not force the gas control knob. Use only your hand to turn the gas knob. Never use any tools.
2. If the gas control knob will not operate by hand, call a qualified service technician to replace the gas control.

GAS CONTROL KNOB SETTINGS

The gas control knob operates differently in intermittent pilot, hot surface and direct spark ignition systems.

The gas control knob settings for an intermittent pilot system are:

OFF: Prevents pilot and main burner gas flow.

ON: Permits gas to flow into the control body. Under control of the thermostat and intermittent pilot module, gas can flow to the pilot and main burner.

The gas control knob settings for hot surface or direct spark ignition systems are:

OFF: Prevents main burner gas flow.

ON: Permits main burner gas flow. Under control of the thermostat and ignition module, gas can flow to the main burner.

NOTE: Gas controls are shipped with the gas control knob in the ON position.

PERFORM GAS LEAK TEST



WARNING

**FIRE OR EXPLOSION HAZARD
 CAN CAUSE PROPERTY DAMAGE,
 SEVERE INJURY, OR DEATH**



Check for gas leaks with a rich soap and water solution anytime work is done on a gas control.

GAS LEAK TEST

1. Paint all pipe connections upstream of the gas control with a rich soap and water solution. Bubbles indicate a gas leak.
2. If a gas leak is detected, tighten the pipe connection.

CAUTION

Stand clear while lighting main burner to prevent injury caused from hidden gas leaks that could cause flashback in the appliance vestibule.

3. Turn on the system by rotating the gas control knob counterclockwise  to ON.
4. Light the main burner by following the appliance manufacturer instructions or turning up the thermostat to call for heat.
5. With the main burner in operation, paint all pipe joints and gas control inlet and outlet with a rich soap and water solution.
6. If another gas leak is detected, tighten joints and pipe connections.
7. If gas leak cannot be stopped, turn the gas control knob clockwise  to OFF.
8. Replace the leaking part.
9. Perform the gas leak test.

ADJUST THE PILOT BURNER FLAME (INTERMITTENT PILOT IGNITION ONLY)

The pilot flame should envelop 3/8 to 1/2 in. (10 to 13 mm) of the igniter-sensor tip. See Fig. 12. To adjust the pilot flame:



1. Remove the pilot adjustment cover screw. Refer to Fig. 4.
2. Turn the inner adjustment screw clockwise  to decrease or counterclockwise  to increase pilot flame.
3. To prevent gas leakage, always replace the cover screw after adjustment.

Fig. 12—Proper flame adjustment.



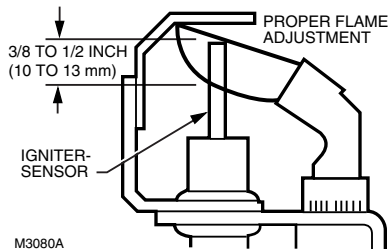

CHECK AND ADJUST GAS INPUT TO MAIN BURNER

CAUTION

1. Do not exceed the input rating stamped on the appliance nameplate, or manufacturer recommended burner orifice pressure for the size orifice(s) used. Make certain the primary air supply to the main burner is properly adjusted for complete combustion (refer to the appliance manufacturer instructions).
2. WHEN CHECKING GAS INPUT BY CLOCKING THE GAS METER:
 - Make sure that the only gas flow through the meter is that of the appliance being checked.
 - Make certain that other appliances are turned off with pilot burners extinguished (or deduct that gas consumption from the meter reading).
 - Convert the flow rate to Btuh as described in Gas Controls Handbook, form 70-2602, and compare to the Btuh input rating on the appliance nameplate.
3. WHEN CHECKING GAS INPUT WITH A MANOMETER (PRESSURE GAUGE):
 - To connect the manometer, be sure the gas control knob is in the OFF position before removing the outlet pressure tap plug.
 - When removing the manometer, turn the gas control knob back to OFF and replace the outlet pressure tap plug.
 - Shut off the gas supply at the appliance service valve, or at the gas tank for LP gas, before removing the outlet pressure tap plug and before disconnecting the manometer and replacing the outlet pressure tap plug.
 - Perform the Gas Leak Test at the outlet pressure tap plug.

Standard-Opening Pressure Regulator

1. The gas control outlet pressure should match the manifold pressure listed on the appliance nameplate.
2. With the main burner operating, check the gas control flow rate by using the meter clocking method or check the gas pressure using a manometer connected to the gas control outlet pressure tap. See Fig. 4.
3. If necessary, adjust the pressure regulator to match the appliance rating. Refer to Table 5 for the factory-set nominal outlet pressures and adjustment setting ranges.
 - a. Remove the pressure regulator adjustment cap screw.
 - b. Using a screwdriver, turn the inner adjustment screw clockwise  to increase or counterclockwise  to decrease the main burner gas pressure.
 - c. Always replace the cap screw and tighten firmly to safeguard proper operation.

4. If the desired outlet gas pressure or gas flow rate cannot be achieved by adjusting the gas control, check the gas control inlet pressure by using a manometer at the inlet pressure tap. If the inlet pressure is in the normal range (refer to Table 5), replace the gas control. Otherwise, take the necessary steps to provide proper gas pressure to the gas control.

TABLE 5—PRESSURE REGULATOR
SPECIFICATION PRESSURES FOR STANDARD-
OPENING NATURAL GAS.

Unit of Measure	Nominal Inlet Pressure Range	Outlet Pressure (Full Rate)	
		Nominal Factory Outlet Setting	Adjustment Setting Range
in. wc	5.0 - 7.0	3.5	3.0 - 5.0
kPa	1.2 - 1.7	0.9	0.7 - 1.2

CHECK SAFETY SHUTDOWN PERFORMANCE



WARNING

**FIRE OR EXPLOSION HAZARD
CAN CAUSE PROPERTY DAMAGE,
SEVERE INJURY, OR DEATH**

Perform the safety shutdown test any time work is done on a gas system.

NOTE: Read steps 1 through 7 below before starting and compare to the safety shutdown or safety lockout tests recommended for the intermittent pilot (IP), hot surface (HSI) or direct spark (DSI) module. When different, use the procedure recommended for the module.

1. Turn off gas supply.
2. Set the thermostat or controller above room temperature to call for heat.
3.
 - *Intermittent Pilot Ignition*—Watch for an ignition spark at pilot burner either immediately or following prepurge. See ignition module specifications.
 - *Hot Surface or Direct Spark Ignition*—Watch for an ignition spark or glow at hot surface igniter either immediately or following prepurge. See ignition module specifications.
4. If module has timed ignition, time the length of the igniter operation. See ignition module specifications.
5.
 - *Intermittent Pilot Ignition*—After the module locks out, turn on gas supply and make sure there is no gas flow to the pilot or main burner.

NOTE: With modules that continue spark until pilot lights or system is shut down manually, pilot should light when gas supply is turned on.

- *Hot Surface or Direct Spark Ignition*—After the module locks out, turn on gas supply and assure there is no gas flow to main burner.
6. Set the thermostat below room temperature and wait at least 45 seconds to reset system.
 7. Operate system through one complete cycle to make sure all controls operate properly.

Maintenance



WARNING

**FIRE OR EXPLOSION HAZARD
CAN CAUSE PROPERTY DAMAGE,
SEVERE INJURY, OR DEATH**

Improper cleaning or reassembly can cause gas leakage. When cleaning, be sure that the control is reassembled properly and perform gas leak test.

Regular preventive maintenance is important in applications that place a heavy load on system controls such as commercial cooking, agricultural and industrial operations because:

- In many such applications, particularly commercial cooking, the equipment operates 100,000 to 200,000 cycles per year. Such heavy cycling can wear out the gas control in one to two years.
- Exposure to water, dirt, chemicals and heat can damage the gas control and shut down the control system.

The maintenance program should include regular check-out of the gas control; see Startup and Checkout section. To check out the control system, see the appliance manufacturer literature. Maintenance frequency must be determined individually for each application. Some considerations are:

- *Cycling frequency*. For appliances that may cycle 100,000 times annually, check monthly.
- *Intermittent use*. For appliances that are used seasonally, check before shutdown and again before the next use.
- *Consequence of unexpected shutdown*. Where the cost of an unexpected shutdown would be high, check the system more often.
- *Dusty, wet, or corrosive environment*. Because these environments can cause the gas control to deteriorate more rapidly, check the system more often.

NOTE: If the gas control will be exposed to high ammonia conditions; e.g., those used in greenhouses or animal barns, contact your Honeywell sales representative to request a gas control with corrosion resistant construction.

The gas control should be replaced if:

- It does not perform properly during checkout or troubleshooting.
- The gas control knob is hard to turn or push down.
- The gas control is likely to have operated for more than 200,000 cycles.

Operation

The VR8345 gas controls provide ON-OFF manual control of gas flow. In the OFF position, pilot and/or main burner gas flow is prevented. In the ON position, pilot and/or main burner gas flow is under control of the thermostat, the direct spark ignition (DSI) module, hot surface ignition (HSI) module/intermittent pilot module, and the gas valve.

DIRECT SPARK IGNITION/HOT SURFACE IGNITION APPLICATIONS

System Operation

When the thermostat calls for heat, the DSI OR HSI module is energized. The module activates the first and second automatic valves of the gas control, which allows main burner gas flow. At the same time, the DSI/HSI module generates a spark at the igniter-sensor to light the main burner.

The second automatic valve diaphragm, controlled by the servo pressure regulator, opens and adjusts gas flow as long as the system is powered. The servo pressure regulator monitors outlet pressure to provide an even main burner gas flow. Loss of power (thermostat satisfied) de-energizes the DSI/HSI module and closes the automatic valves. The system is ready to return to normal service when power is restored through the thermostat.

If the igniter-sensor stops detecting a flame at the main burner, the trial for ignition is restarted. On DSI/HSI modules with lockout timers, the automatic valves are de-energized and ignition stops after the lockout period. On modules without lockout timers, the trial for ignition continues indefinitely and the first automatic valves remain open.

If main burner flame is restarted successfully, operation continues as described above. Gas control operation is described in more detail below.

Valve Position During Thermostat OFF Cycle

The valve is positioned as shown in Fig. 13 when the:

- gas control knob is in the ON position.
- thermostat is not calling for heat.

The first automatic valve is closed. The second automatic valve operator is de-energized, closing the channel to the pressure regulator, and opening a channel to the underside of the second automatic valve diaphragm. The combination of spring pressure under the second automatic valve diaphragm and lack of outlet pressure hold the diaphragm firmly closed. Main burner gas flow is blocked by both valves.

When Thermostat Calls for Heat

When the thermostat calls for heat, the DI module generates a spark at the main burner and the first automatic

valve and second automatic valve operators are energized, Fig. 14. The first automatic valve opens, and the second automatic valve operator valve disk is lifted off its seat. This diverts gas flow from the second automatic valve diaphragm, and causes a reduction of pressure on the underside of this diaphragm. The reduced pressure on the bottom of the automatic valve diaphragm repositions the diaphragm downward, away from the valve seat, allowing main burner gas flow.

INTERMITTENT PILOT APPLICATIONS

System Operation

When the thermostat calls for heat, the S8600 Intermittent Pilot Module is energized. The S8600, in turn, activates the first automatic valve of the gas control, allowing pilot gas flow. Simultaneously, the S8600 module generates a spark at the igniter-sensor and lights the pilot. The pilot flame is then sensed by the igniter-sensor, and spark generation ends.

After the pilot is lit, the S8600 module energizes the solenoid for the second automatic valve operator. (The first automatic valve remains energized.)

The second automatic valve diaphragm, controlled by servo pressure regulator, opens and adjusts main gas flow as long as the system is powered and the pilot is burning. The servo pressure regulator monitors outlet pressure to provide an even main burner gas flow. Loss of power (thermostat satisfied) de-energizes the S8600 module and closes both automatic valves. The system is then ready for the next cycle.

Loss of pilot flame, or when flame is too small to reliably light the main burner, closes the second automatic valve operator. The S8600 module then attempts to restart the pilot. On S8600 modules with lockout timers, the first automatic valve closes after the lockout period. On S8600 modules without lockout timers, the trial for ignition continues indefinitely and the first automatic valve remains open.

If pilot flame is restarted successfully, main burner is reopened, and gas flows to the main burner as described above. Gas control operation is described in more detail below.

Valve Position During Thermostat Off Cycle

The valve is positioned as shown in Fig. 15 when the:

- manual gas control knob is in the ON position.
- thermostat is not calling for heat.

The first automatic valve is closed. The second automatic valve operator is de-energized, closing the channel to the pressure regulator, and opening a channel to the under-

side of these second automatic valve diaphragm. The combination of spring pressure under the second automatic valve diaphragm and lack of outlet pressure hold the diaphragm firmly closed. (Gas pilot burner gas flow is prevented by the first automatic valve and main burner by both valves.)

When Thermostat Calls for Heat

When the thermostat calls for heat, the trial for pilot ignition begins. The first automatic valve solenoid is energized by the module and opens, allowing pilot burner gas flow. Gas also flows to the second automatic valve operator, but is mechanically blocked at the operator. See Fig. 13.

After the pilot lights and the pilot flame is sensed by the igniter-sensor, the second automatic valve solenoid is energized by the module, and the second automatic operator valve is lifted off its seat. See Fig. 14. This diverts gas flow from the second automatic valve diaphragm and causes a reduction of pressure on the underside of this diaphragm. The reduced pressure on the bottom of the automatic valve diaphragm repositions the diaphragm downward, away from the valve seat, allowing main burner gas flow.

ALL APPLICATIONS

During the ON cycle, the servo pressure regulator provides close control of outlet pressure, even if inlet pressure and flow rate vary widely. Any outlet pressure change is

immediately reflected back to the pressure regulator diaphragm, which repositions to change the flow rate through the regulator and, thus, through the automatic valve.

If outlet pressure begins to rise, the pressure regulator diaphragm moves slightly higher, allowing less gas flow to the gas control outlet. This increases gas pressure under the automatic valve diaphragm and repositions the valve disk closer to the seat. Thus, flow of gas through the second automatic valve is reduced, and outlet pressure falls to the desired level.

If outlet pressure begins to fall, the pressure regulator diaphragm moves slightly lower, allowing more gas flow to the gas control outlet. This decreases gas pressure under the second automatic valve diaphragm and repositions the valve disk further from the seat. Thus, flow of gas through the second automatic valve is increased, and outlet pressure rises to the desired level.

When the Call for Heat Ends

When the call for heat ends, the first automatic valve and the second automatic valve operator close, bypassing the regulator(s) and shutting off the main burner (and in the intermittent pilot application, the pilot gas flow). As pressure inside the gas control and underneath the automatic valve diaphragm equalizes, spring pressure closes the second automatic valve to provide a second barrier to gas flow.

Fig. 13—Intermittent Pilot Applications: Position of gas control components during trial for pilot ignition.

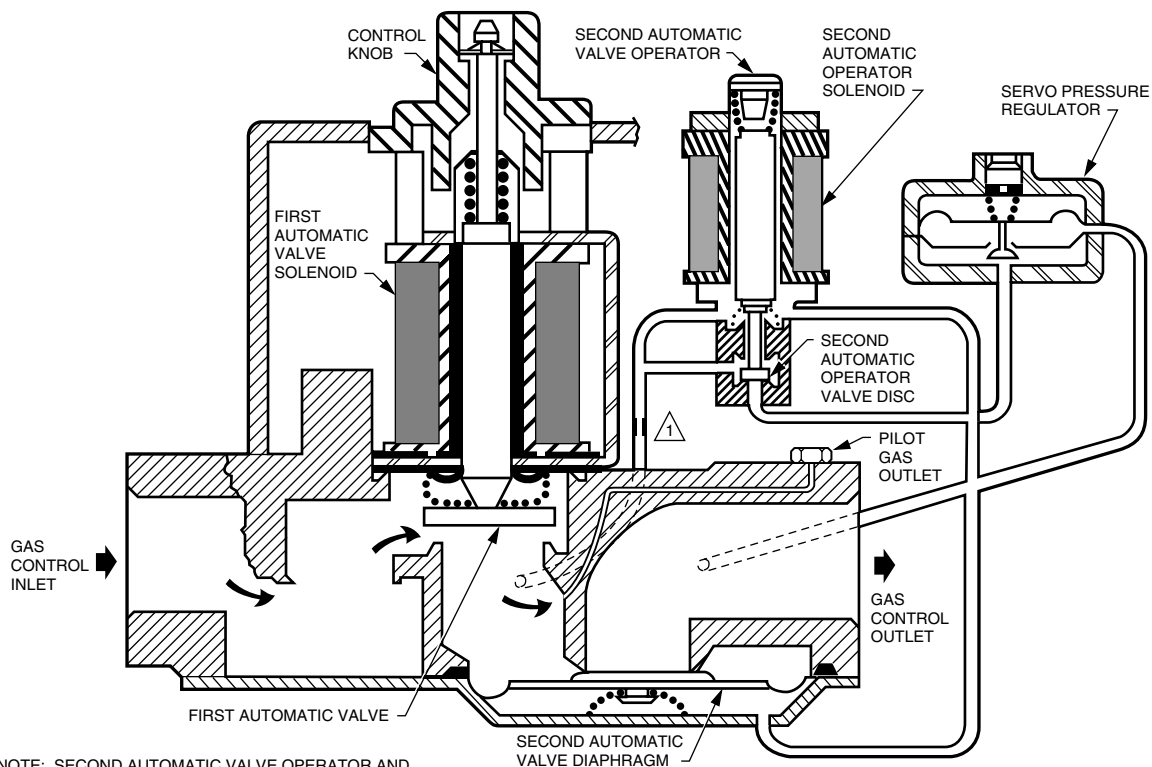

NOTE: SECOND AUTOMATIC VALVE OPERATOR AND SERVO PRESSURE REGULATOR SHOWN OUTSIDE GAS CONTROL FOR EASE IN TRACING GAS FLOW. 1 SLOW-OPENING GAS CONTROL HAS A GAS FLOW RESTRICTOR IN THIS PASSAGE. M9127

Fig. 14—Direct Ignition/Intermittent Pilot Applications: Position of gas control components during burner on cycle.

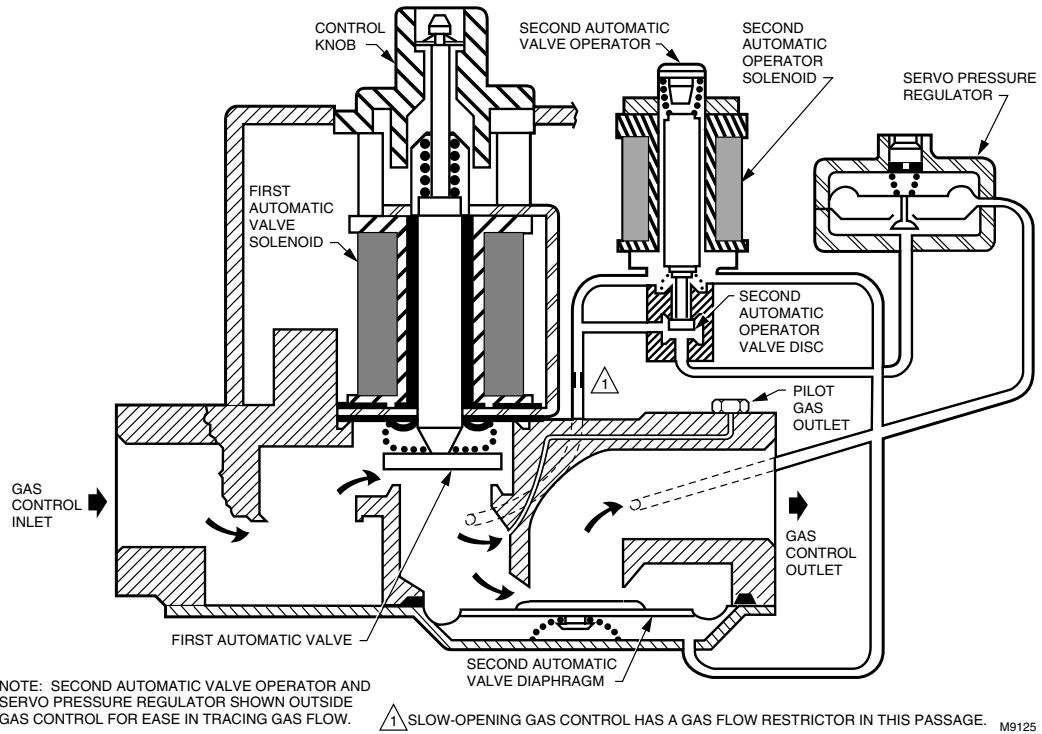
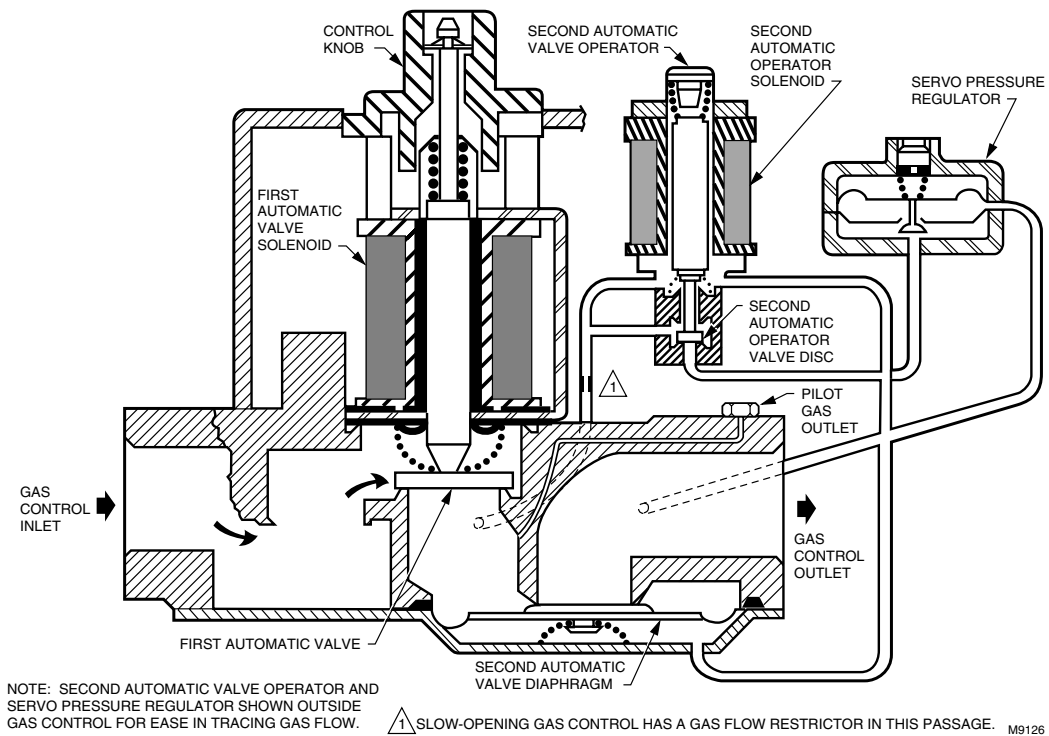

Fig. 15—Direct Ignition/Intermittent Pilot Applications: Position of gas control components during thermostat off cycle.



Service



WARNING

FIRE OR EXPLOSION HAZARD CAN CAUSE PROPERTY DAMAGE, SEVERE INJURY OR DEATH

Do not disassemble the gas control; it contains no replaceable components. Attempted disassembly or repair can damage the gas control.



CAUTION

Do not apply a jumper across or short the valve coil terminals. Doing so can burn out the heat anticipator in the thermostat or damage the ignition module.

IF MAIN BURNER WILL NOT COME ON WITH CALL FOR HEAT

1. Make sure the gas control knob is in the ON position.
2. Adjust the thermostat several degrees above room temperature.

INSTRUCTIONS TO THE HOMEOWNER (FOR YOUR SAFETY, READ BEFORE OPERATING)



WARNING

FIRE OR EXPLOSION HAZARD CAN CAUSE PROPERTY DAMAGE, SEVERE INJURY, OR DEATH

Follow these warnings exactly:

1. Pilot/main burner flame is lit automatically. Do not light the pilot/main burner flame manually.
2. Before lighting appliance, smell around the appliance for gas. Be sure to smell next to the floor because LP gas is heavier than air.
3. IF YOU SMELL GAS:
 - Turn off the gas supply at the appliance service valve. On LP gas systems, turn off gas supply at the gas tank.
 - Do not light any appliances in the house.
 - Do not touch electrical switches or use phone.
 - Leave the building and use a neighbor's phone to call your gas supplier.
 - If you cannot reach your gas supplier, call the fire department.
4. Do not force the gas control knob. Use only your hand to push down or turn the gas control knob. Never use any tools. If the gas control knob will not operate by hand, call a qualified service technician to replace the gas control. Force or attempted repair can result in a fire or explosion.
5. Call a qualified service technician to replace the gas control if it has been flooded with water.
6. Replace the gas control in the event of any physical damage, tampering, bent terminals, missing or broken parts, stripped threads, or evidence of exposure to heat.

3. Using an ac voltmeter, check for voltage at the gas control.

- *Intermittent Pilot Ignition*—If pilot lights, measure voltage across MV/PV and MV. If pilot does not light, measure across MV/PV and PV before safety lockout occurs.
- *Hot Surface or Direct Spark Ignition*—Measure voltage across MV terminals at gas control.



4. If voltage is not present, check control circuit for proper operation.
5. If proper control circuit voltage is present, replace gas control.

IMPORTANT: *Follow the operating instructions provided by the manufacturer of your heating appliance. The information below will be helpful in a typical gas control application, but the specific controls used and the procedures outlined by the manufacturer or your appliance may differ and require special instructions.*

TO TURN ON THE APPLIANCE

Stop: Read the Warnings on page 11.

The pilot/main burner flame is lit automatically. *Do not attempt to manually light the pilot.* If the appliance does not turn on when the thermostat is set several degrees above room temperature, follow these instructions:

1. Set the thermostat to its lowest setting to reset the safety control.
2. Disconnect all electric power to the appliance.
3. Remove the gas control access panel.
4. Push in the gas control knob slightly and turn clockwise  to OFF.
5. Wait five minutes to clear out any unburned gas. If you then smell gas, STOP! Follow step 3 of the Warning in the Instructions To The Homeowner section. If you do not smell gas, continue with the next step.
6. Turn the gas control knob counterclockwise  to ON.
7. Replace the gas control access panel.
8. Reconnect all electric power to the appliance.
9. Set the thermostat to the desired setting.
10. If the appliance does not turn on, set the gas control knob to OFF and contact a qualified service technician for assistance.

TURNING OFF THE APPLIANCE

VACATION SHUTDOWN—Set the thermostat to the desired room temperature while you are away.

COMPLETE SHUTDOWN—Push in the gas control knob slightly and turn clockwise  to OFF. Do not force. Appliance will completely shut off. Follow the Instructions to the Homeowner above to resume normal operation.

Honeywell

Home and Building Control

Honeywell Inc.
1985 Douglas Drive North
Golden Valley, MN 55422

Home and Building Control

Honeywell Limited—Honeywell Limitée
740 Ellesmere Road
Scarborough, Ontario
M1P 2V9

Helping You Control Your World

Printed in U.S.A.



Printed on recycled paper containing at least 10% post-consumer paper fibers.

QUALITY IS KEY