

## 208427 Replacement Power Supply Kits for Electronic Air Cleaners

### INSTALLATION INSTRUCTIONS

#### APPLICATION

These kits replace the power supplies with solid-state performance indicators (SSPI) used in the F50, F52, F57, and F90 Electronic Air Cleaners. See Table 1. Each kit includes the power supply and leadwires.



#### CAUTION

**Electric Shock Hazard.**  
**Can cause electrical shock or equipment damage.**  
 Disconnect power before removing or installing power supply board.

Table 1. Power Supply Replacement Guide.

Supply Model	Voltage	Nominal Size of Electronic Cell(s)		Ionizer Current (mA)	J6 Position	Replacement Power Supply (OS no.)	Air Flow Switch
		(in.)	(mm)				
F50E	120 Vac	16 x 25	406 x 635	1.65	2	208427AB	No
		20 x 20	508 x 508	1.65	2	208427AB	
		20 x 25	508 x 635	2.1	3	208427AB	
	240 Vac	16 x 25	406 x 635	1.65	2	208427AC	
		20 x 20	508 x 508	1.65	2	208427AC	
		20 x 25	508 x 635	2.1	3	208427AC	
F52E (One Cell)	120 Vac	20 x 12-1/2	508 x 318	1.05	N/A	208427H	
	220-240 Vac, 50 Hz			1.05	N/A	208427E	
F52E (Two Cell)	120 Vac	20 x 25	508 x 635	2.1	N/A	208427A	
	220-240 Vac, 50 Hz			2.1	N/A	208427G	
F57A (Two Cell)	120 Vac	20 x 25	508 x 635	2.1	N/A	208427C	
	220-240 Vac, 50 Hz			2.1	N/A	208427Q	
F57B (One Cell)	120 Vac	20 x 12-1/2	508 x 318	0.9	N/A	208427K	
	220-240 Vac			0.9	N/A	208427T	
F90A (Two Cell)	120 Vac	20 x 25	508 x 635	2.1	N/A	208427D	
	220-240 Vac, 50 Hz			2.1	N/A	208427S	
F90B (One Cell)	120 Vac	20 x 12-1/2	508 x 318	0.9	N/A	208427L	
	220-240 Vac, 50 Hz			0.9	N/A	208427U	
F52F (One Cell)	120 Vac	20 x 12-1/2	508 x 318	1.05	N/A	208427J	Yes
	220-240 Vac, 50 Hz			1.05	N/A	208427N	
F52F (Two Cell)	120 Vac	20 x 25	508 x 635	2.1	N/A	208427AA	
	240 Vac			2.1	N/A	208427Z	



## INSTALLATION

### When Installing this Product...

1. Read these instructions carefully. Failure to follow them could damage the product or cause a hazardous condition such as electrical shock.
2. Check the ratings given in the instructions and on the product to make sure the product is suitable for your application.
3. Installer must be a trained, experienced service technician.
4. After installation is complete, check out product operation as provided in these instructions.

## **!** WARNING

**Electric Shock Hazard.  
Safety Hazard.**

**Can cause electrical shock or equipment damage.**

Disconnect power before removing old power supply board and installing replacement power supply board. When servicing the F57 or F90, stand on a stable work platform or ladder.

### TWO-CELL MODEL

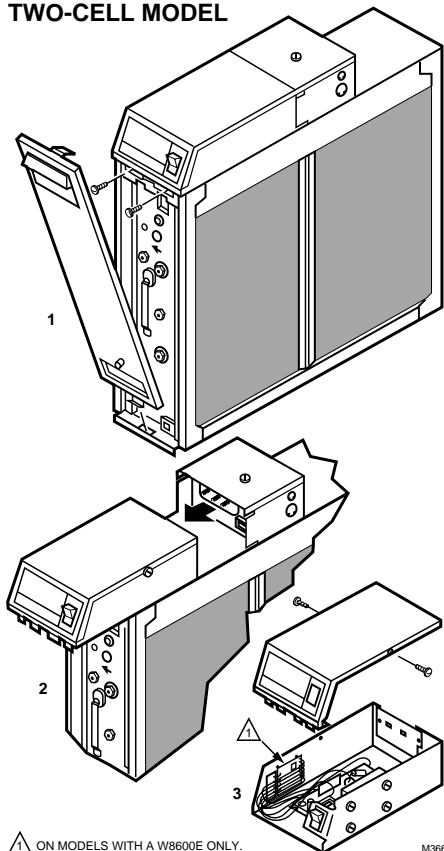

**!** ON MODELS WITH A W8600E ONLY.

M3663

**Fig. 1. Power supply location on F50E  
Two-Cell Air Cleaners.**

### To Remove Old Power Supply Board And Performance Indicator Board

**NOTE:** It is advisable to observe the location of leadwires on the power supply to be replaced. Tagging the lead-wires as they are removed will help to correctly reconnect them.

- Open access door or grille. See Figs. 1 through 5.
- Open power box.
- Remove W8600E terminal block and wiring. Save screws for future use.
- On the F90, remove the power supply assembly as follows:
  - Open the cover by pulling the two latches located on the front of the cover and swinging the cover down until it hangs (see Fig. 5).
  - Remove the two prefilters and the two cells from the channel guides.
  - Loosen the screws holding the power supply assembly cover plate and remove the cover plate. See Fig. 6.
  - Loosen the two screws on the inner wall of the power supply assembly and three screws on the top of the assembly. Slide the power supply assembly toward the center of the air cleaner and disconnect the two Molex connectors and the one quick connect connector. See Fig. 6.
  - Remove the power supply assembly to a table or work bench to replace the power supply.
- Disconnect the red ionizer and black collector leads at the board quick connects.
- Disconnect remaining input leads at the quick connects.
- Remove and set aside the sheet metal screws holding the power supply board in place. Remove the performance indicator board by clipping the four plastic standoffs with diagonal cutters, or squeezing the ends of the standoffs to release the board. Remove and discard the board.

**ONE-CELL MODEL**

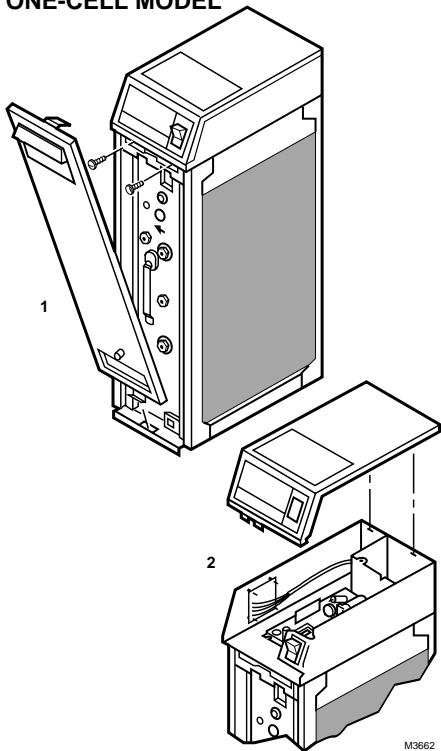

**Fig. 2. Power supply location on F50 One Cell.**

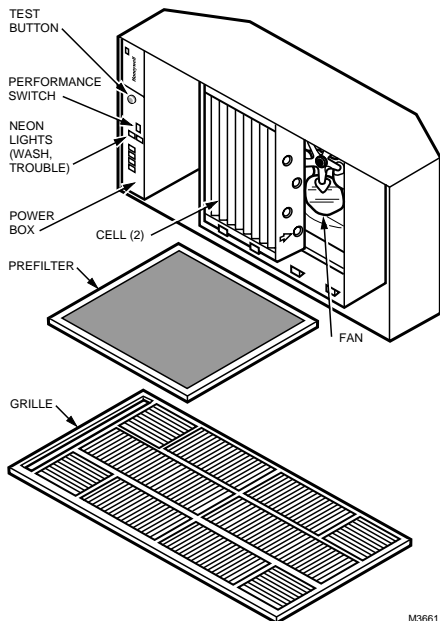

**Fig. 4. Power box location on F57 Air Cleaners. Open to access power supply.**

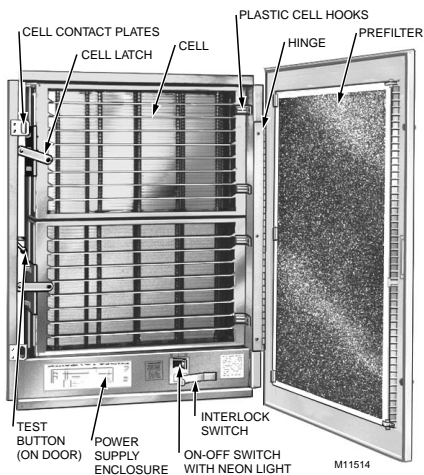

**Fig. 3. Power supply enclosure location on F52 Air Cleaner. Open to access power supply.**

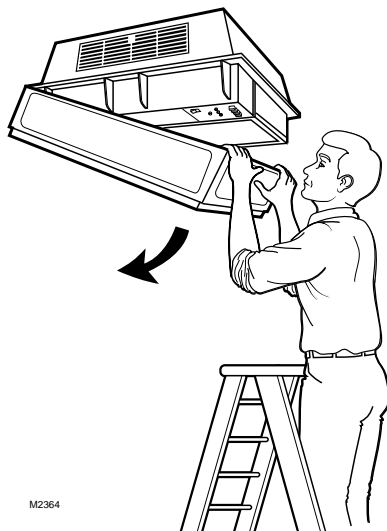

**Fig. 5. Opening the F90A Cover.**

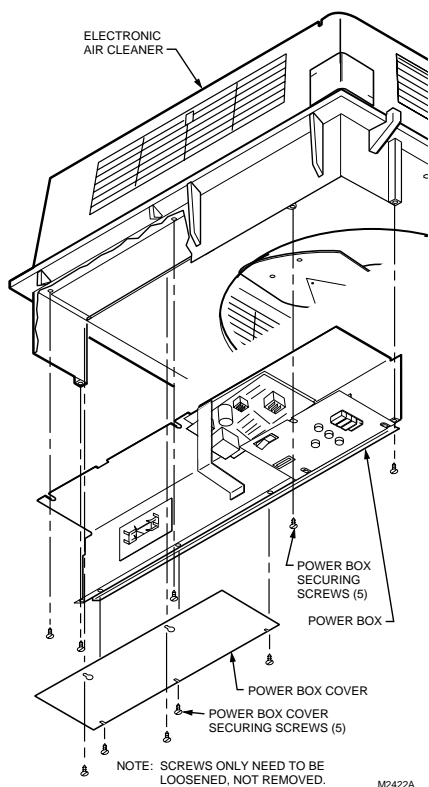

**Fig. 6. Removing F90A Power Supply Assembly.**

### Install New Power Supply

- When replacing the power supply, refer to the appropriate wiring diagram. See Figs. 7-11.
- Install new W8600E terminal block and wiring using screws removed previously.
- When replacing the power supply, reuse the lead wires remaining in the air cleaner when removing the old power supply board and performance indicator board.
- Note that the F52 uses a mounting plate that has a rubber bumper; turn over the power supply and pry the rubber bumper off the bottom.
- Align the mounting holes and mount the new power supply in the air cleaner using the sheet-metal screws removed earlier. Orient the terminal strip (on selected models) so that pin 1 is at the top.

### IMPORTANT

*Do not splice ionizer and collector leads. These leads must be unbroken to avoid electrical shock through the connector or tape covering the splice.*

- Route the remaining leads so the red ionizer and black collector leads are separate from the power supply and light leads. Route all leads around, rather than over, the power supply board. Keep all leads away from high voltage leads. On single-cell, duct mounted cleaners, route the performance indicator output lead (4-wire thermostat cable) to the rear of the power supply assembly.
- Connect the leads to the quick-connect terminals on the new power supply. See Figs. 7 through 11.
- Route the leads through the cable clamp and hook the cable clamp to the tab on the left front of the power supply. Push down the tab to hold the cable clamp in place. See Fig. 15.

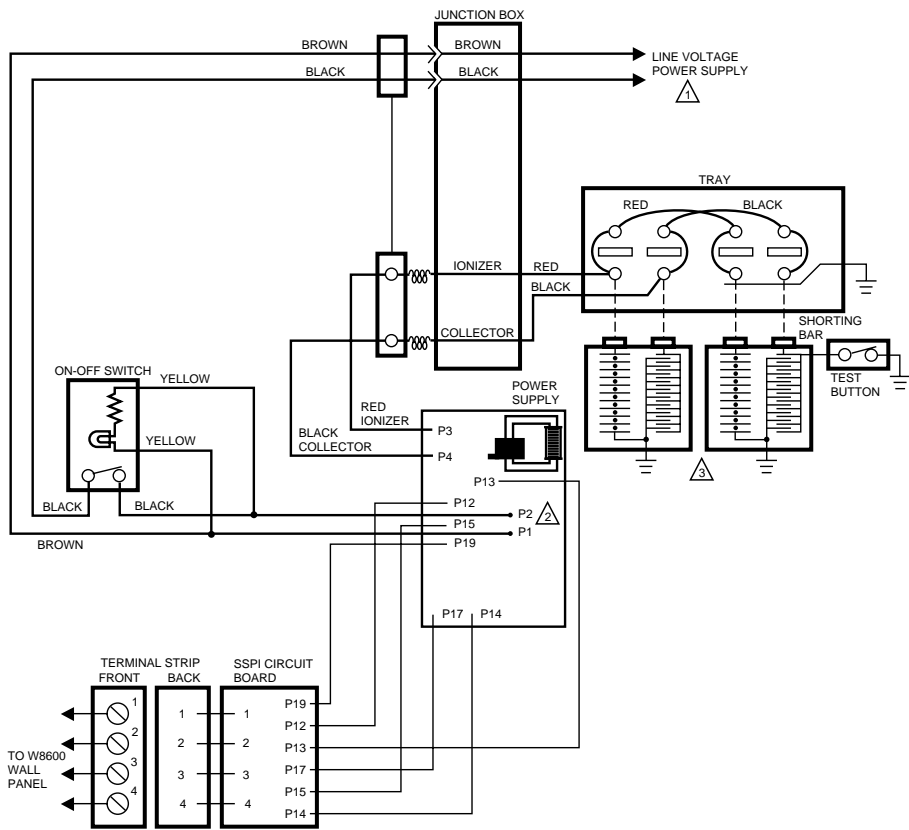

- ⚠ POWER SUPPLY. PROVIDE DISCONNECT MEANS AND OVERLOAD PROTECTION AS REQUIRED.
- ⚠ P1, P2 TERMINALS ON 120V MODELS ONLY. POWER CONNECTIONS ON 240 V MODELS ARE TO QUICK-CONNECTS ON POWER SUPPLY TRANSFORMER. BROWN LEAD GOES TO TOP TERMINAL AND BLACK LEAD TO BOTTOM TERMINAL.
- ⚠ ONE-CELL UNIT SIMILAR, BUT WITH JUST ONE CELL.
- ⚠ ON ONE-CELL, DUCT-MOUNTED UNITS, SSPI OUTPUT LEAD IS A 4-WIRE CABLE.

M3016B

**Fig. 7A. Past electronic air cleaner (F50A&E, F52E) with W8600E—internal schematic.**

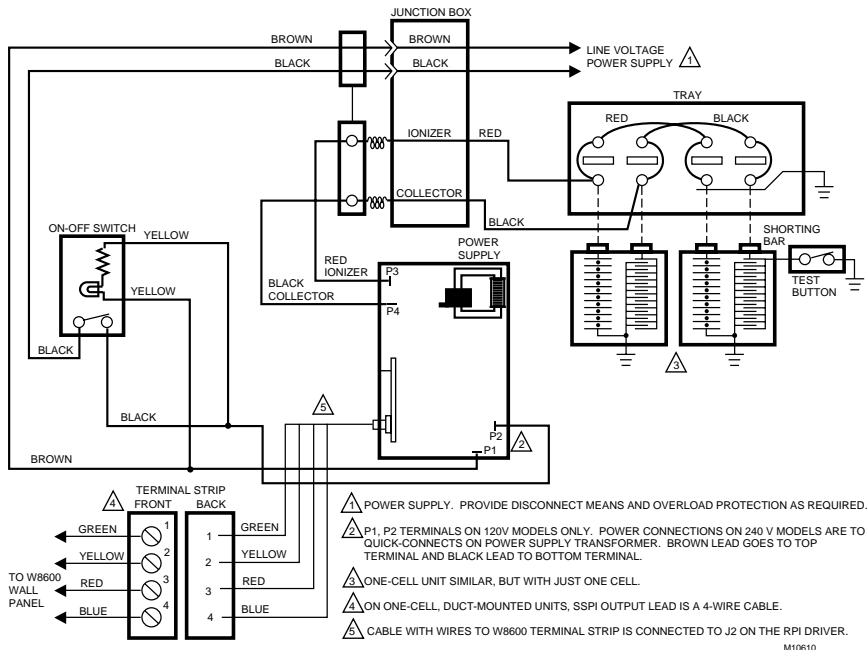
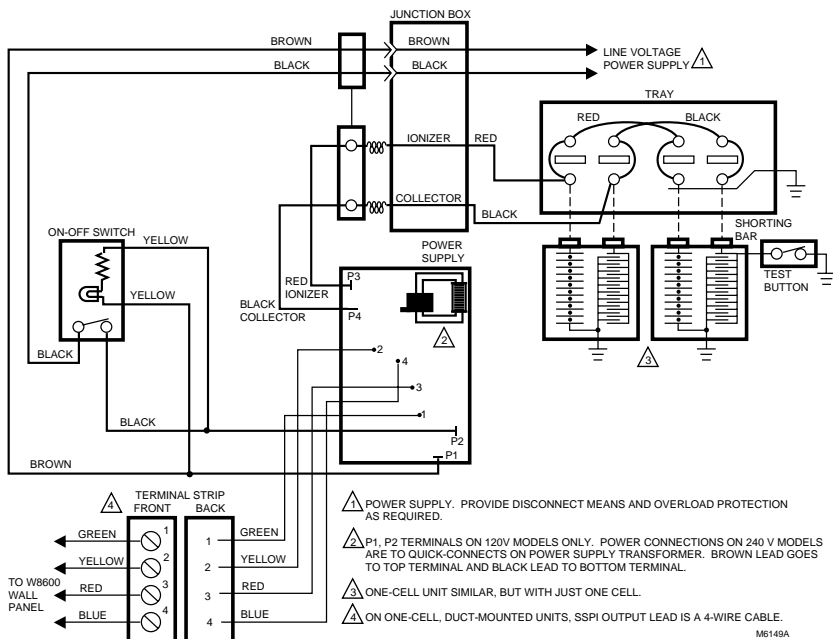



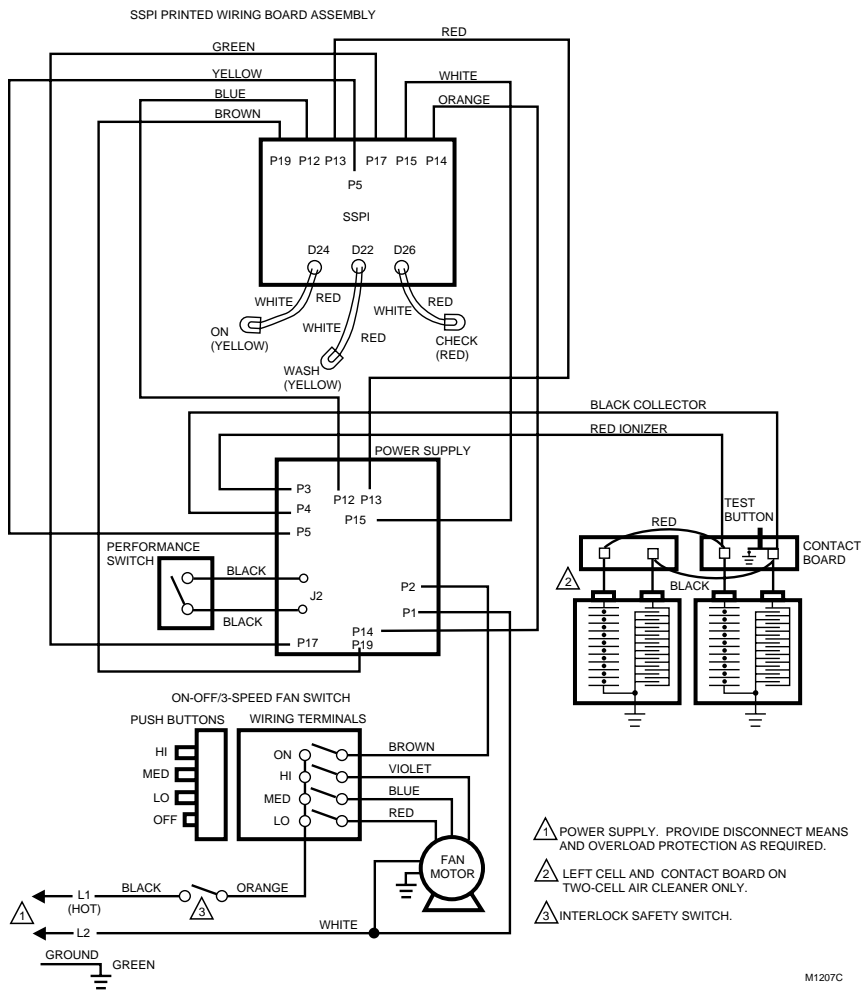

Fig. 9A. Past F57 120V model electrical schematic.

M1207C

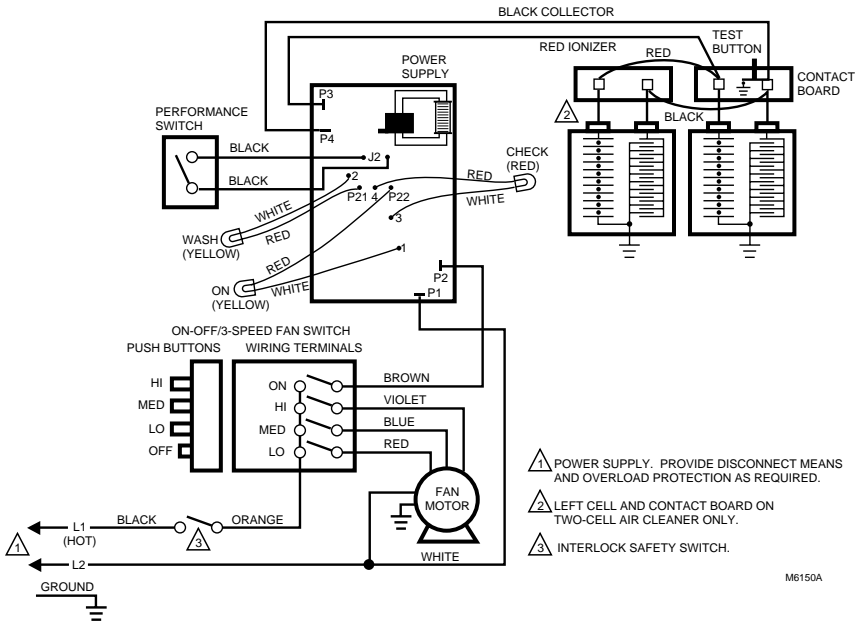
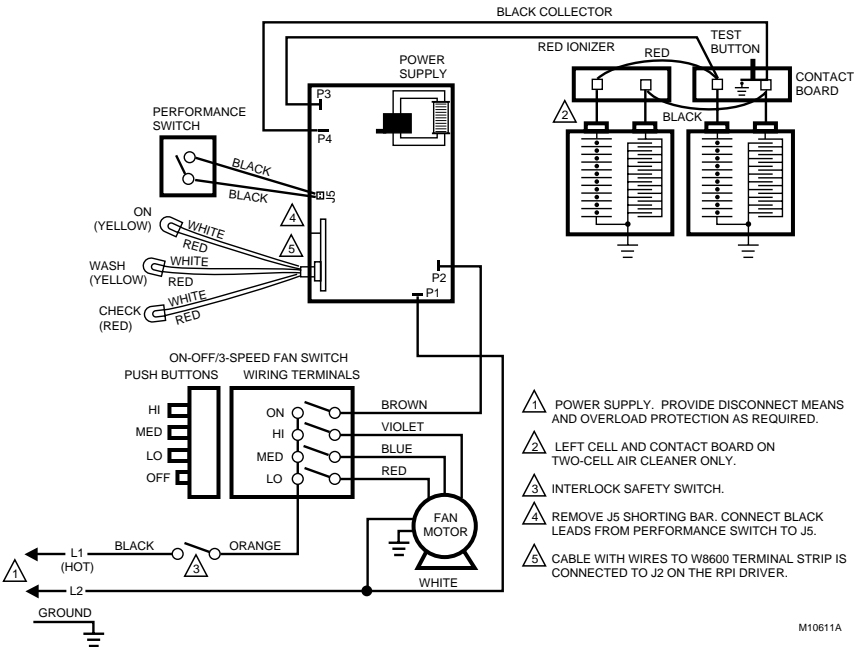

Fig. 9B. Recent F57 120V model electrical schematic.



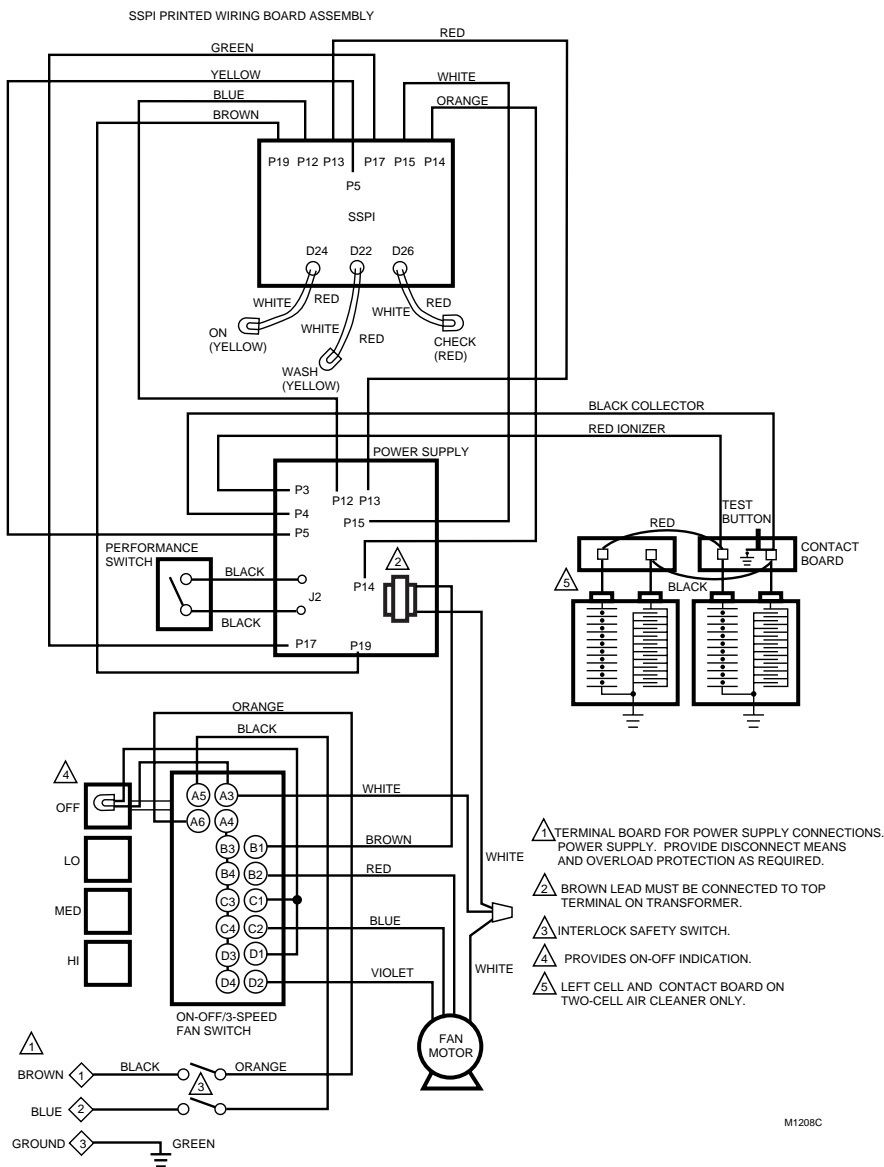

Fig. 10A. Past F57 220-240V model electrical schematic.

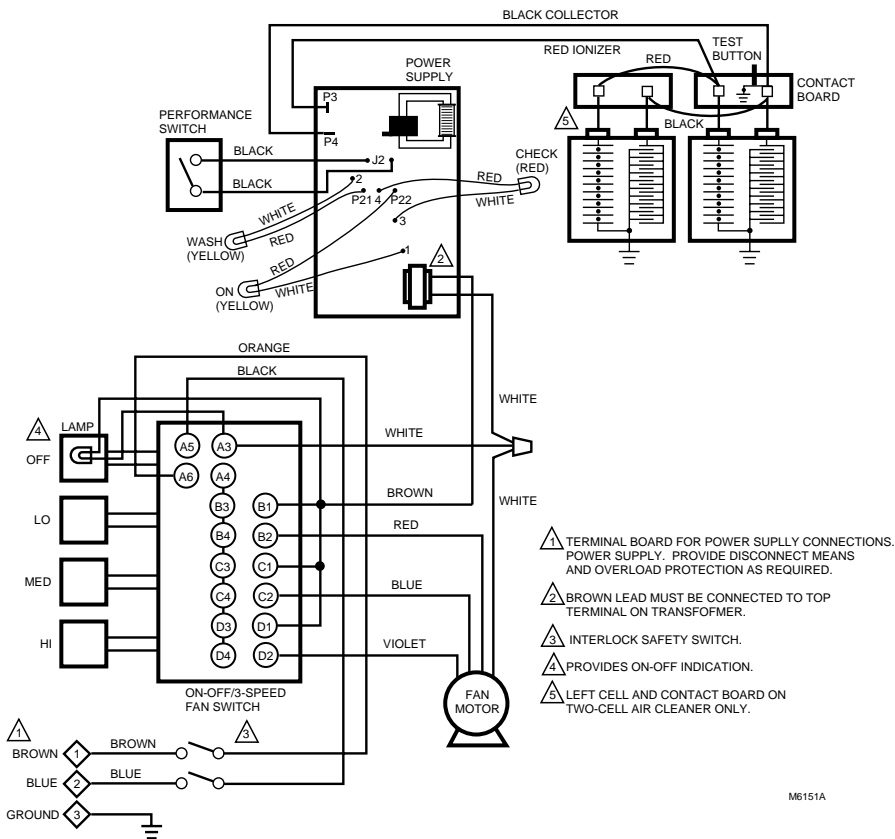

Fig. 10B. Recent F57 220-240V model electrical schematic.

M6151A

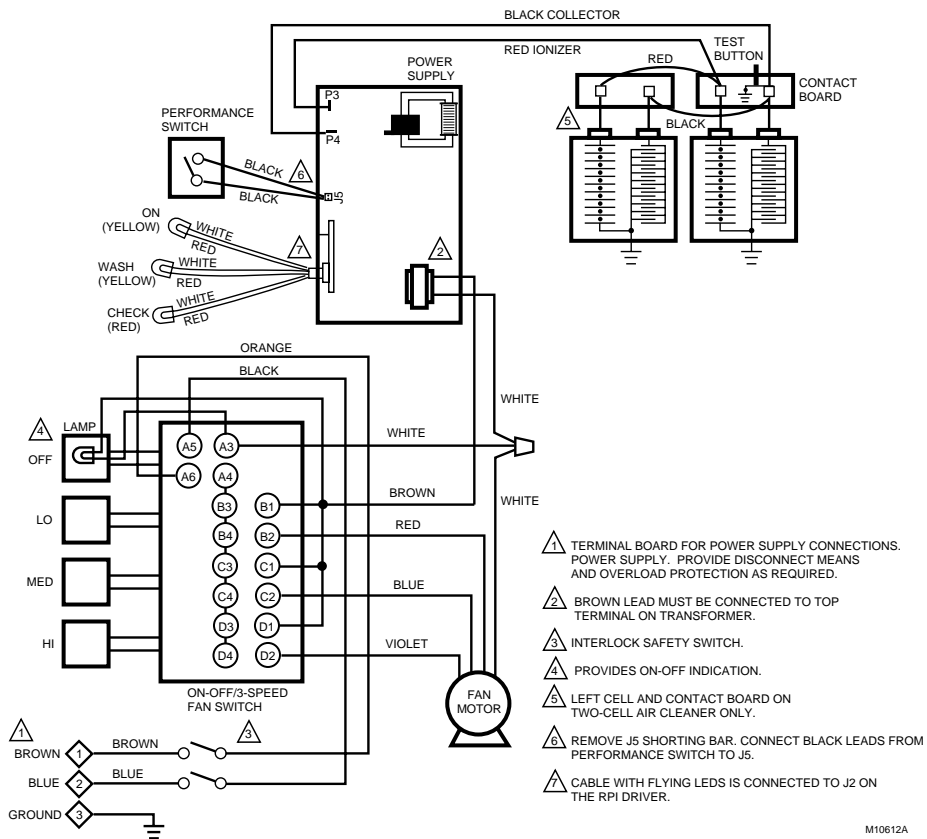

Fig. 10C. Retrofitted/original equipment F57 220-240V model electrical schematic.

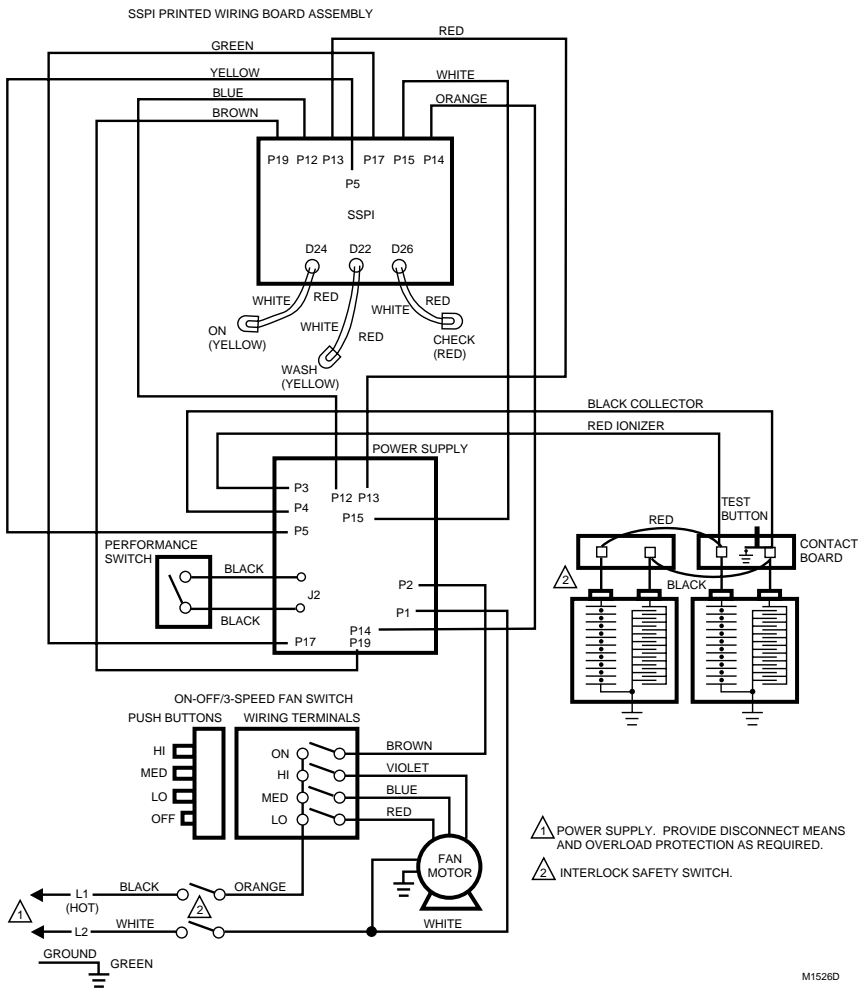

Fig. 11A. Past F90 schematic diagram.



## CHECKOUT

### WARNING

**Electric Shock Hazard.**  
**Can cause personal injury or equipment damage.**

The following procedures expose hazardous live parts. Disconnect power supply between checks and proceed carefully.

### CAUTION

The following instructions are for use only by qualified personnel.

With all components in place, turn on the air cleaner switch and, for forced air (ducted) systems, energize the system blower. Check the following points of operation:

1. Verify the neon light or ON light is lighted. The neon light comes on to show that the air cleaner is energized.
2. Turn off the system blower. The neon light or ON light should go off.
3. Turn the system blower back on. With the air cleaner energized, push the test button. A snapping sound indicates that collector voltage is available.
4. With a multispeed blower, repeat steps 1 through 3 for each fan speed.
5. If operation is not as described, refer to the Troubleshooting and Service section.

## TROUBLESHOOTING AND SERVICE

### WARNING

**Electric Shock Hazard.**  
**Can cause personal injury or equipment damage.**

The following procedures expose hazardous live parts. Disconnect power supply between checks and proceed carefully.

### CAUTION

The following instructions are for use only by qualified personnel.

### Tools and Equipment

Troubleshooting the electronic air cleaner requires:

- Needlenose pliers for stringing ionizer wires and inserting edge connectors.
- Test meter with 15 kVdc probe or equivalent. The electronic air cleaner troubleshooting charts, Figs. 12 and 13, show how to quickly isolate a problem in the air cleaner. Although a meter is needed for some steps, see Fig. 14, the primary diagnostic tools are the *neon light* and the *test button*.

### Test Button

When pushed, the *test button* shorts from collector voltage to ground. See internal schematics, Figs. 7 through 11. The resulting arcing sounds indicate that high voltage is being supplied to the collector. The solid-state power supply controls current flow to the collector.

### Power Supply

### WARNING

**Electric Shock Hazard.**  
**Can cause personal injury.**

Always turn off power and remove access door or grille before removing power box or its cover.

The solid state power supply assembly has no field serviceable components. When troubleshooting indicates a power supply or solid state performance indicator problem, replace the entire power supply assembly.

TROUBLESHOOTING AIR CLEANERS WITH SOLID STATE PERFORMANCE INDICATOR.

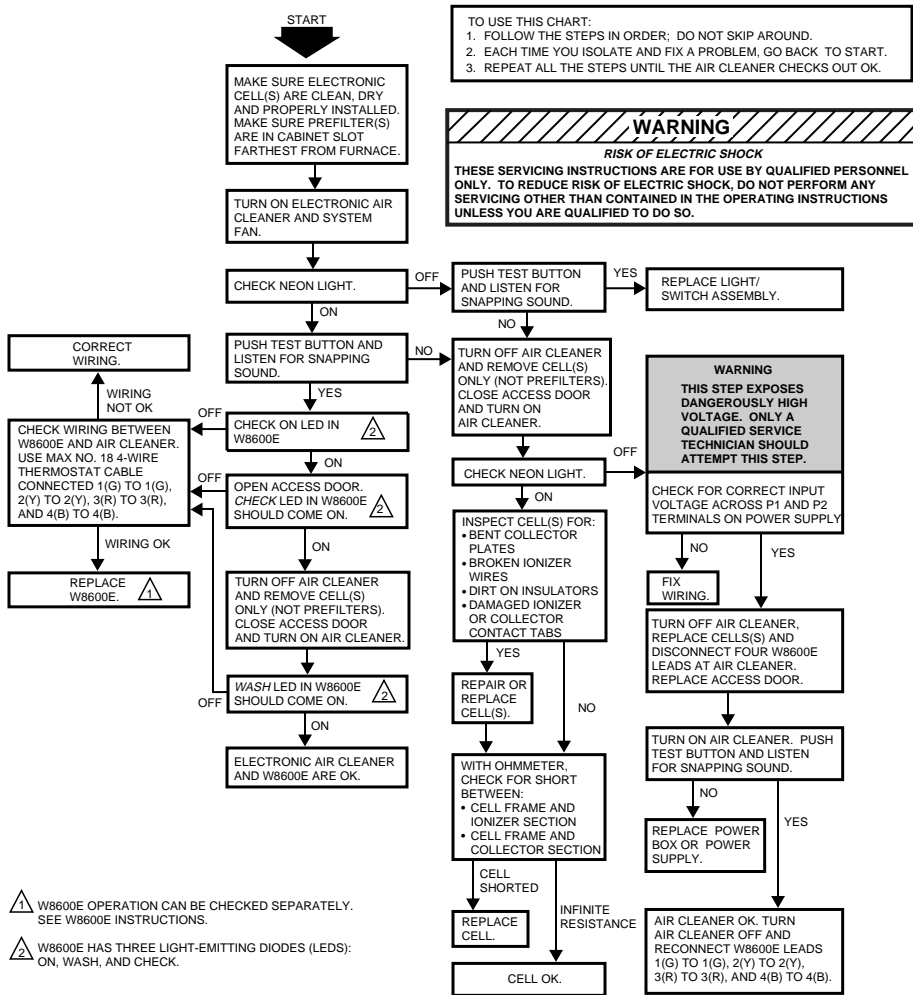

- 1. W8600E OPERATION CAN BE CHECKED SEPARATELY. SEE W8600E INSTRUCTIONS.
- 2. W8600E HAS THREE LIGHT-EMITTING DIODES (LEDS): ON, WASH, AND CHECK.

Fig. 12. Troubleshooting air cleaners with solid-state performance indicator.



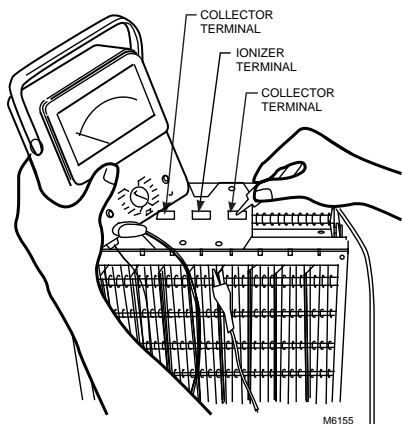

Fig. 14. Use ohmmeter to check electronic cells for short circuits.

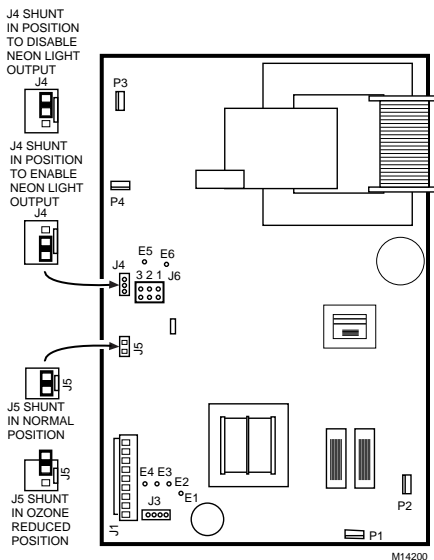

Fig. 15. Move J5 shunting bar to reduce ozone production about 20 to 25 percent..

### Modification To Reduce Ozone Odor

#### **⚠ WARNING**

**Electric Shock Hazard.**  
**Can cause personal injury.**

Always disconnect power before opening the power supply cover.

The electronic air cleaner generates a small amount of ozone in normal operation. During the first or second week of operation, the amount may be higher because of sharp edges on some of the new high voltage metal parts. Normal use quickly dulls these edges.

The average person can detect the odor of ozone in concentrations as low as 0.003 to 0.010 parts per million (ppm). The electronic air cleaner contributes 0.005 to 0.010 ppm of ozone to the indoor air. The U.S. Food and Drug Administration and Health and Welfare Canada recommend that indoor ozone concentration does not exceed 0.050 ppm. As a comparison, the *outdoor* ozone level in major cities is sometimes as high as 0.100 ppm.

However, if desired, the ozone generated by the air cleaner can be reduced in one of three ways:

1. Install an activated carbon filter downstream from the air cleaner. Make sure particles from the air filter cannot fall into the air cleaner.

#### **⚠ WARNING**

**Electric Shock Hazard.**  
**Can cause personal injury.**

Only a trained service technician should perform the following procedure.

2. On F57 and F90 models, make sure the performance switch is in the low position.
3. On all models, the procedure explained below will reduce ozone production about 20 to 25 percent, and efficiency about 7 to 10 percent.
  - a. Turn off power to the air cleaner.
  - b. Open the access door or grille to discharge the high-voltage power supply.
  - c. If power supply is remotely mounted, make sure access door or grille is open. Remove the power box cover.
  - d. Locate J5 shunting bar on the power supply. See Fig. 15. Remove the shunting bar and reinstall on only one pin.

NOTE: This reduces to ozone, but the shunting bar is available for reinstallation if needed.

- e. Replace power supply cover and access door or grille. Turn on power.
- f. Repeat checkout procedure before leaving the job.

## LIMITED TWO-YEAR WARRANTY

Honeywell warrants this product to be free from defects in the workmanship or materials, under normal use and service, for a period of two (2) years from the date of purchase by the consumer. If, at any time during the warranty period, the product is defective or malfunctions, Honeywell shall repair or replace it (at Honeywell's option) within a reasonable period of time.

If the product(s) is defective, please contact:

- a) the dealer from whom you purchased it, or
- b) the local Honeywell Authorized Repair Station, or
- c) the local Honeywell Home and Building Control Sales Office, or
- d) the Honeywell Customer Assistance Center toll free at 1-800-468-1502.  
or
- e) package the defective cell, power supply or other component with care, along with a bill of sale, receipt, or other dated proof of purchase, and a short description of the malfunction, and ship it, prepaid, to the following address:  
Honeywell, Inc.  
Return Goods Department  
1050 Berkshire Lane  
Plymouth, MN 55441-4437

This warranty does not cover removal or reinstallation costs. This warranty shall not apply if it is shown by Honeywell that the defect or malfunction was caused by damage that occurred while the product was in the possession of a consumer.

Honeywell sole responsibility shall be repair or replace the product within the terms stated above. HONEYWELL SHALL NOT BE LIABLE FOR ANY LOSS OR DAMAGE OF ANY KIND, INCLUDING ANY INCIDENTAL OR CONSEQUENTIAL DAMAGES RESULTING, DIRECTLY OR INDIRECTLY, FROM ANY BREACH OF ANY WARRANTY, EXPRESS OR IMPLIED, OR ANY OTHER FAILURE OF THIS PRODUCT. Some states do not allow the exclusion or limitation of incidental or consequential damages, so this limitation may not apply to you.

THE WARRANTIES SET FORTH HEREIN ARE EXCLUSIVE, AND HONEYWELL EXPRESSLY DISCLAIMS ALL OTHER WARRANTIES, WHETHER WRITTEN, ORAL, IMPLIED OR STATUTORY, INCLUDING BUT NOT LIMITED TO ANY WARRANTIES OF MERCHANTABILITY, WORKMANSHIP, OR FITNESS FOR A PARTICULAR PURPOSE.

This warranty gives you specific legal rights, and you may have other rights which vary from state to state.

If you have any questions concerning this warranty, please write our Customer Assistance Center, Honeywell Inc., P.O. Box 524, MN27-2164, Minneapolis, Minnesota 55440-0524 or call toll-free at 1-800-468-1502, Monday-Friday, 7:00 a.m.-5:30 p.m. Central time. In Canada, Honeywell Limited/Honeywell Limitee, 155 Gordon Baker Road, North York, Ontario M2H 3N7.

**Honeywell**

---

**Home and Building Control**  
Honeywell Inc.  
Honeywell Plaza  
P.O. Box 524  
Minneapolis, MN 55408-0524

**Home and Building Control**  
Honeywell Limited-Honeywell Limitée  
155 Gordon Baker Road  
North York, Ontario  
M2H 3N7